

## **Exhibit 28**

Diffuser Piping System Drawings

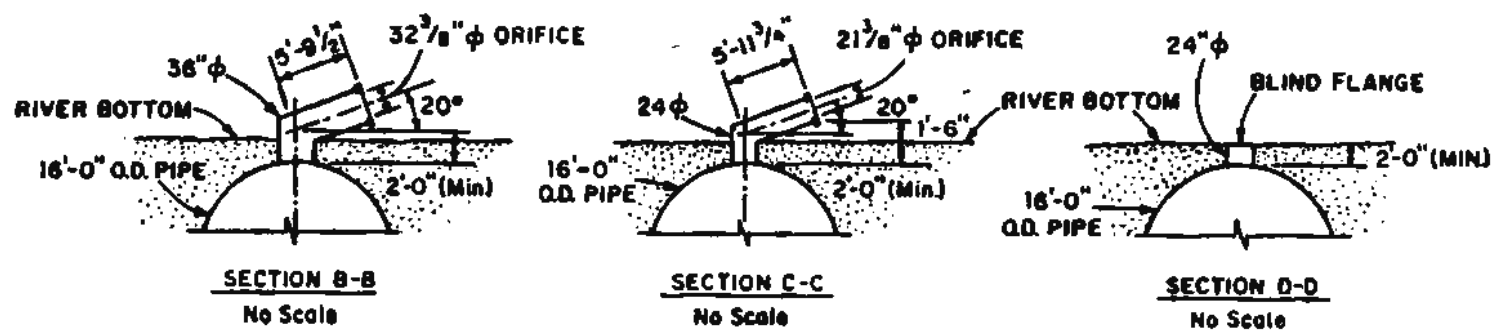
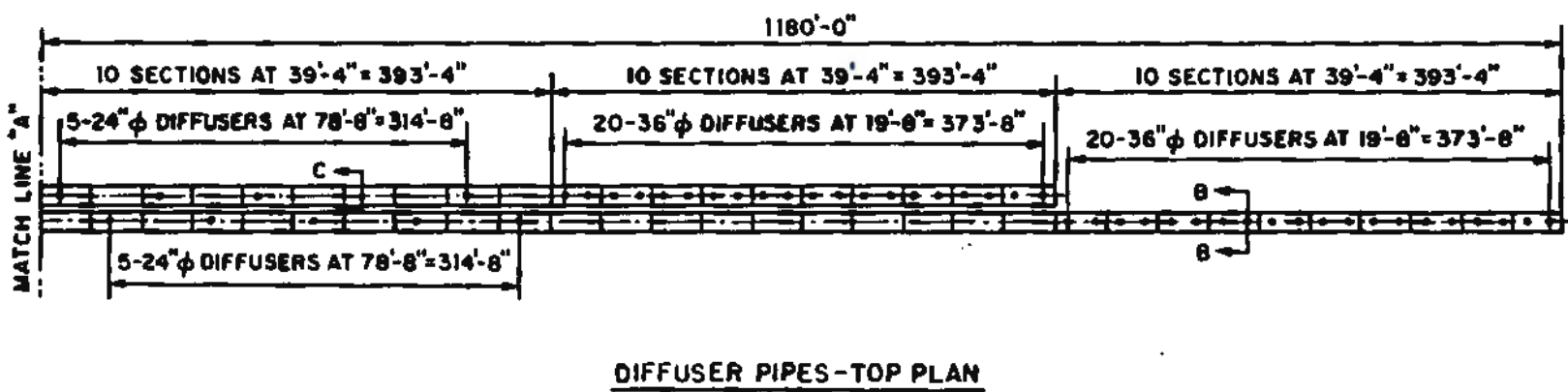
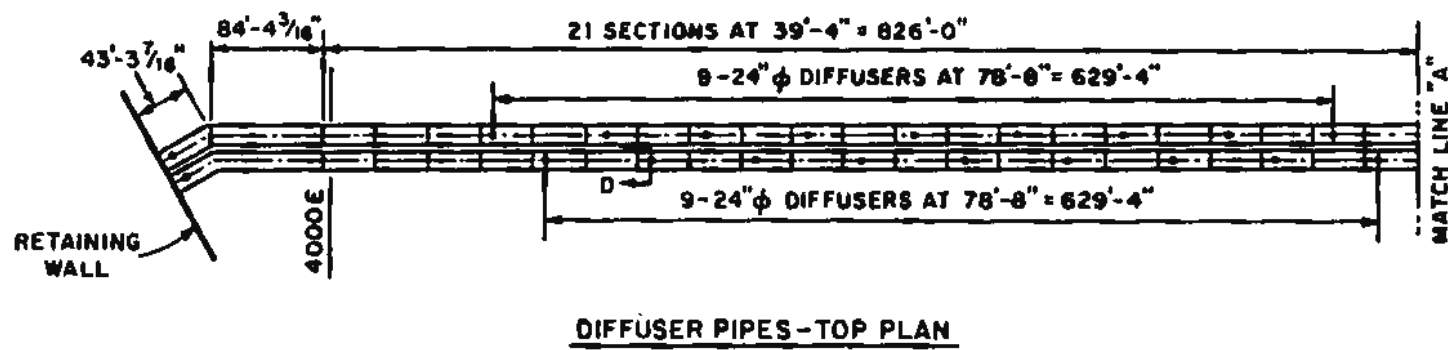
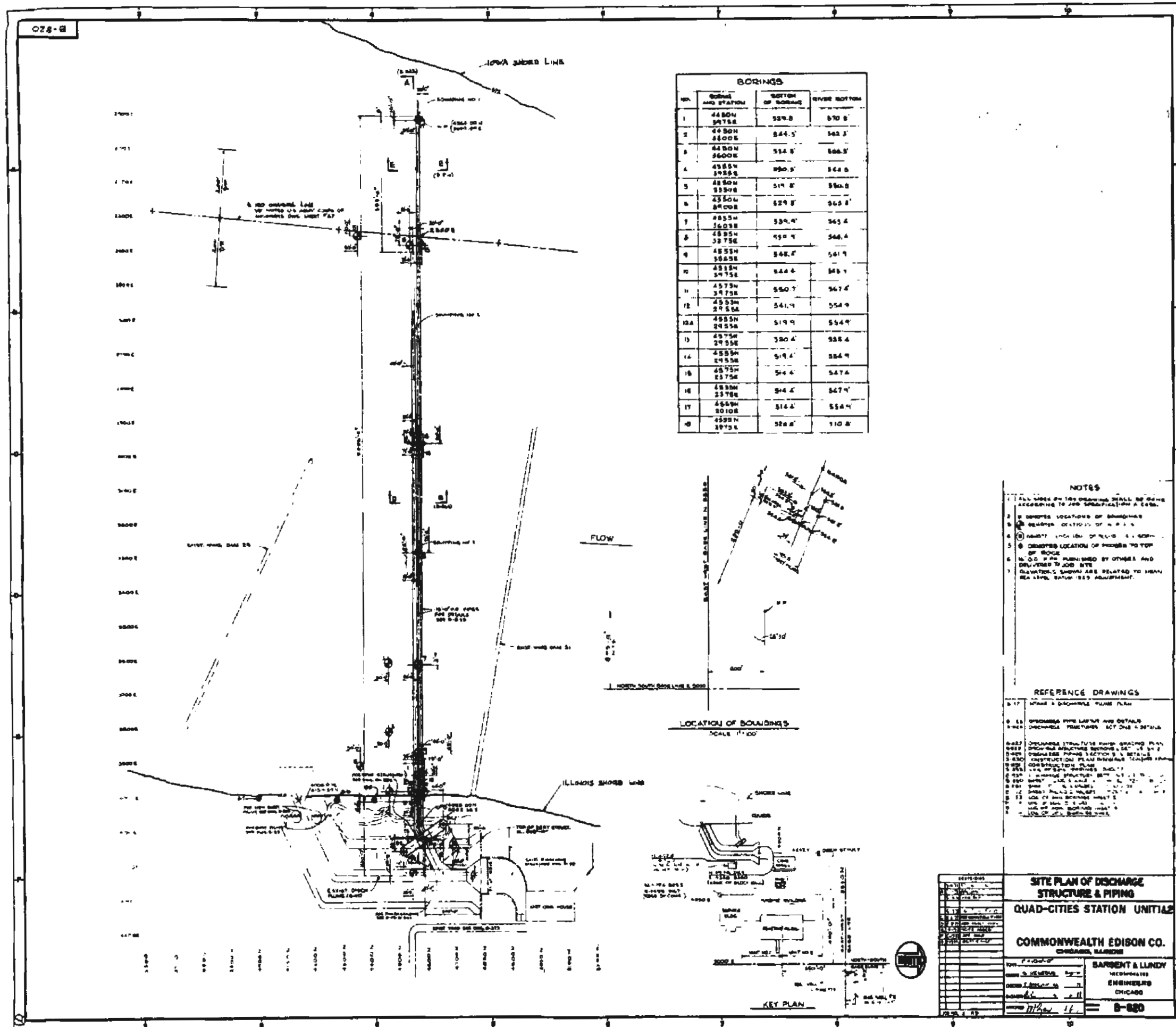
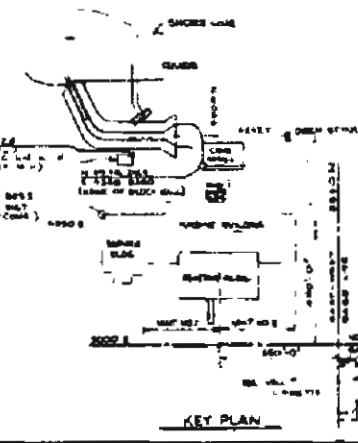

Figure 1. Existing diffuser-pipe system.



BORINGS			
NO.	SOUTH AND STATION	SOUTH OF BORING	DEPTH BOTTOM
1	44 80N 3475E	529.8	570.8
2	44 80N 3400E	544.5	582.5
3	44 80N 2600E	554.8	588.8
4	45 55N 3455E	550.5	584.5
5	45 55N 3390E	519.8	550.8
6	45 55N 3400E	529.8	560.8
7	45 55N 3603E	539.4	563.4
8	45 55N 3475E	499.4	540.4
9	45 55N 3555E	548.4	561.4
10	45 55N 3475E	544.4	565.4
11	45 75N 3475E	550.7	567.7
12	45 55N 2755E	541.4	554.4
12A	45 55N 2455E	519.4	534.4
13	45 75N 2755E	530.4	538.4
14	45 55N 2455E	514.4	524.4
15	45 75N 2375E	514.4	524.4
16	45 55N 2375E	514.4	527.4
17	45 55N 2010E	514.4	524.4
18	45 55N 3975E	528.4	510.4



- NOTES**
1. ALL WORK ON THIS DRAWING SHALL BE DONE ACCORDING TO THE SPECIFICATIONS A.C.S.P.
  2. SEE BORING LOCATIONS OF BORINGS.
  3. SEE BORING LOCATIONS OF BORINGS.
  4. SEE BORING LOCATIONS OF BORINGS.
  5. SEE BORING LOCATIONS OF BORINGS TO TOP OF ROCK.
  6. N.O.C. IF NOT FURNISHED BY OTHERS AND DELIVERED TO JOB SITE.
  7. ELEVATIONS SHOWN ARE RELATED TO MEAN SEA LEVEL, DATUM 1985 ADJUSTMENT.

- REFERENCE DRAWINGS**
- 1. 17. WPA & DISCHARGE PUMP PLAN
  - 2. 18. DISCHARGE PIPE LAYOUT AND DETAILS
  - 3. 19. DISCHARGE STRUCTURE DETAIL & DETAILS
  - 4. 20. DISCHARGE STRUCTURE WITH BRACING PLAN
  - 5. 21. DISCHARGE STRUCTURE SECTION DETAIL
  - 6. 22. DISCHARGE PIPING SECTION DETAIL
  - 7. 23. CONSTRUCTION PLAN BRACING TUBES
  - 8. 24. CONSTRUCTION PLAN
  - 9. 25. W.P.A. PLAN
  - 10. 26. W.P.A. PLAN
  - 11. 27. W.P.A. PLAN
  - 12. 28. W.P.A. PLAN
  - 13. 29. W.P.A. PLAN
  - 14. 30. W.P.A. PLAN
  - 15. 31. W.P.A. PLAN
  - 16. 32. W.P.A. PLAN
  - 17. 33. W.P.A. PLAN
  - 18. 34. W.P.A. PLAN
  - 19. 35. W.P.A. PLAN
  - 20. 36. W.P.A. PLAN
  - 21. 37. W.P.A. PLAN
  - 22. 38. W.P.A. PLAN
  - 23. 39. W.P.A. PLAN
  - 24. 40. W.P.A. PLAN
  - 25. 41. W.P.A. PLAN
  - 26. 42. W.P.A. PLAN
  - 27. 43. W.P.A. PLAN
  - 28. 44. W.P.A. PLAN
  - 29. 45. W.P.A. PLAN
  - 30. 46. W.P.A. PLAN
  - 31. 47. W.P.A. PLAN
  - 32. 48. W.P.A. PLAN
  - 33. 49. W.P.A. PLAN
  - 34. 50. W.P.A. PLAN
  - 35. 51. W.P.A. PLAN
  - 36. 52. W.P.A. PLAN
  - 37. 53. W.P.A. PLAN
  - 38. 54. W.P.A. PLAN
  - 39. 55. W.P.A. PLAN
  - 40. 56. W.P.A. PLAN
  - 41. 57. W.P.A. PLAN
  - 42. 58. W.P.A. PLAN
  - 43. 59. W.P.A. PLAN
  - 44. 60. W.P.A. PLAN
  - 45. 61. W.P.A. PLAN
  - 46. 62. W.P.A. PLAN
  - 47. 63. W.P.A. PLAN
  - 48. 64. W.P.A. PLAN
  - 49. 65. W.P.A. PLAN
  - 50. 66. W.P.A. PLAN
  - 51. 67. W.P.A. PLAN
  - 52. 68. W.P.A. PLAN
  - 53. 69. W.P.A. PLAN
  - 54. 70. W.P.A. PLAN
  - 55. 71. W.P.A. PLAN
  - 56. 72. W.P.A. PLAN
  - 57. 73. W.P.A. PLAN
  - 58. 74. W.P.A. PLAN
  - 59. 75. W.P.A. PLAN
  - 60. 76. W.P.A. PLAN
  - 61. 77. W.P.A. PLAN
  - 62. 78. W.P.A. PLAN
  - 63. 79. W.P.A. PLAN
  - 64. 80. W.P.A. PLAN
  - 65. 81. W.P.A. PLAN
  - 66. 82. W.P.A. PLAN
  - 67. 83. W.P.A. PLAN
  - 68. 84. W.P.A. PLAN
  - 69. 85. W.P.A. PLAN
  - 70. 86. W.P.A. PLAN
  - 71. 87. W.P.A. PLAN
  - 72. 88. W.P.A. PLAN
  - 73. 89. W.P.A. PLAN
  - 74. 90. W.P.A. PLAN
  - 75. 91. W.P.A. PLAN
  - 76. 92. W.P.A. PLAN
  - 77. 93. W.P.A. PLAN
  - 78. 94. W.P.A. PLAN
  - 79. 95. W.P.A. PLAN
  - 80. 96. W.P.A. PLAN
  - 81. 97. W.P.A. PLAN
  - 82. 98. W.P.A. PLAN
  - 83. 99. W.P.A. PLAN
  - 84. 100. W.P.A. PLAN

**SITE PLAN OF DISCHARGE STRUCTURE & PIPING**

**QUAD-CITIES STATION UNIT#2**

**COMMONWEALTH EDISON CO.**  
CHICAGO, ILLINOIS

DATE: 11/11/11

BY: [Signature]

SCALE: 1" = 100'

**BARRETT & LINDY**  
REGISTERED ENGINEERS  
CHICAGO

**B-880**

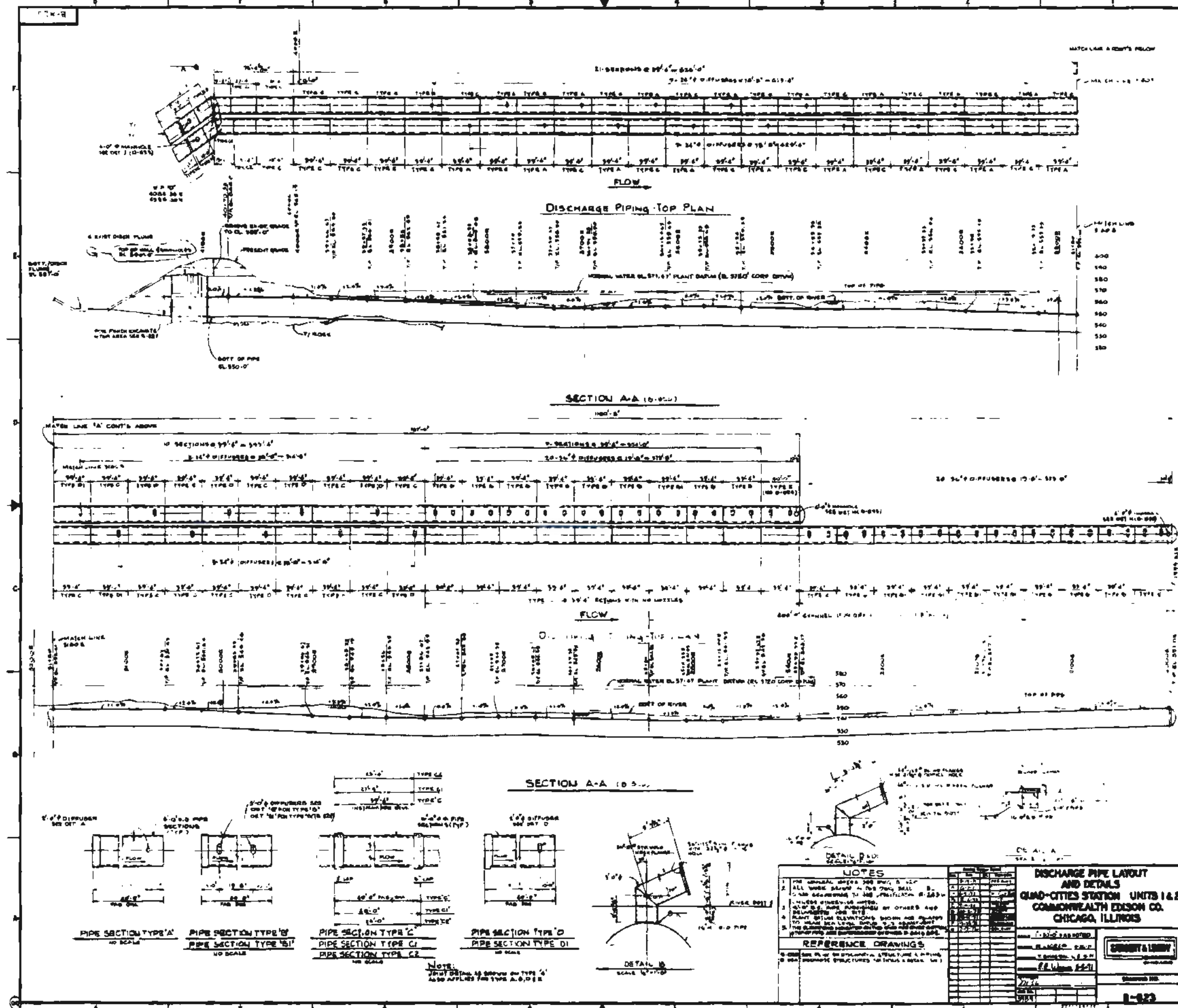

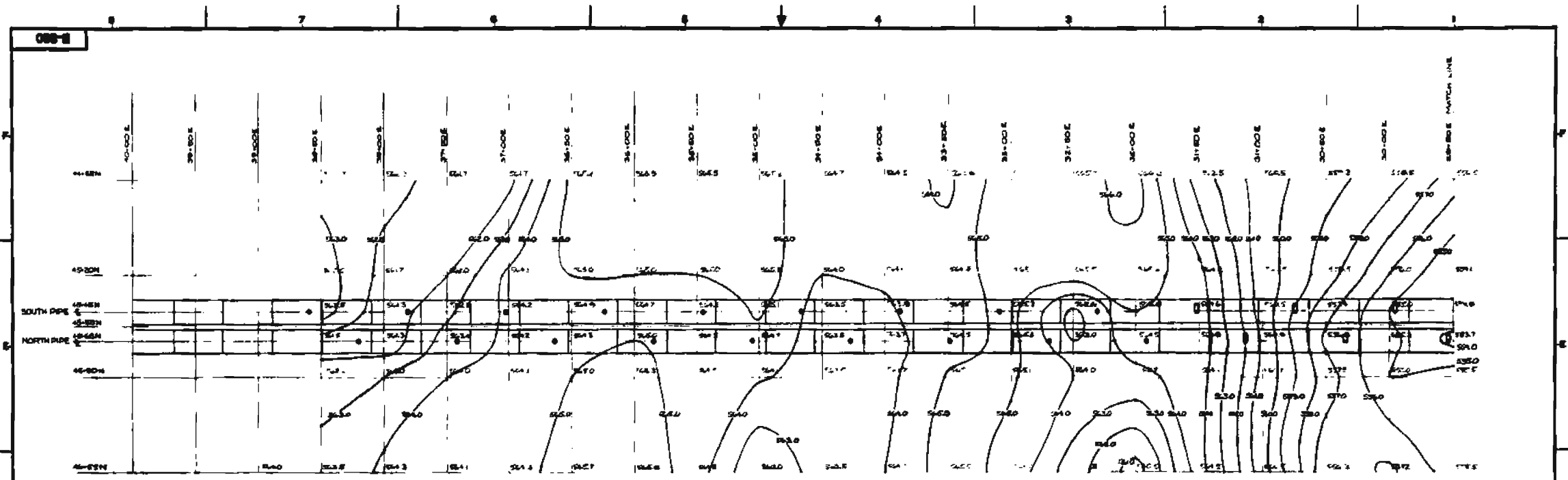

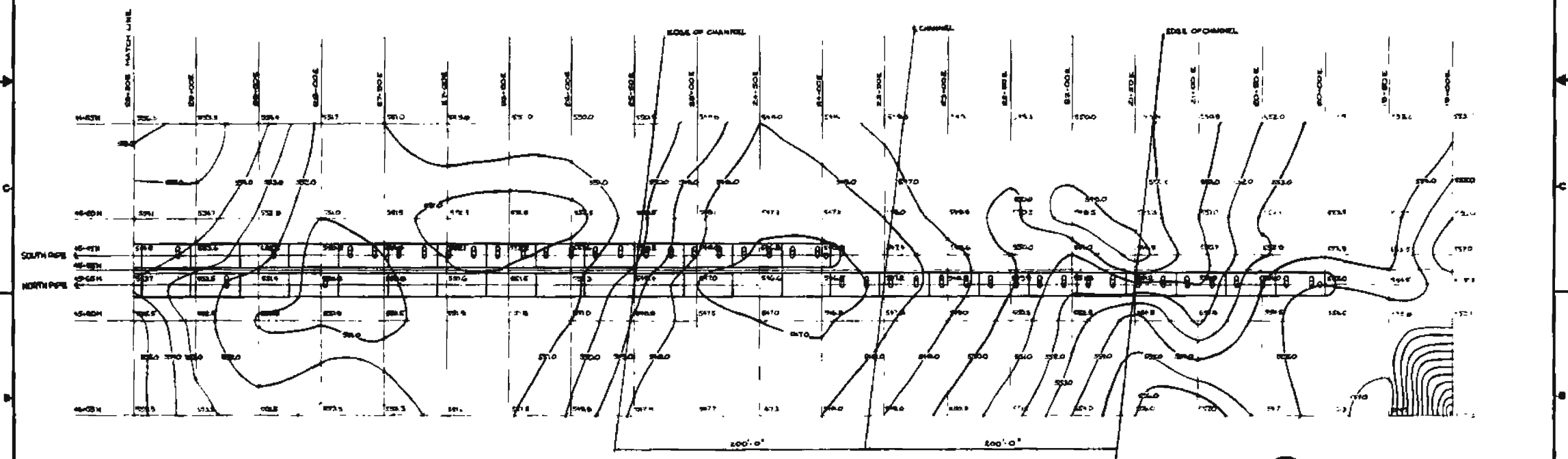

CONTOUR PLAN PIPE DIFFUSERS



CONTOUR PLAN PIPE DIFFUSERS

 B-860 

NOTES	REFERENCE DRAWINGS	REVISIONS	DISCHARGE STRUCTURES CONTOUR PLAN QUAD-CITIES STATION UNITS 1 & 2 COMMONWEALTH EDISON CO. CHICAGO, ILLINOIS																					
1. FOR GENERAL NOTES SEE SHEET B-859 2. ALL WORK SHOWN ON THIS SHEET SHALL BE IN ACCORDANCE WITH THE SPECIFICATIONS TO STANDARD DRAWINGS PUBLISHED BY THE COMPANY.		<table border="1"><thead><tr><th>NO.</th><th>DESCRIPTION</th><th>DATE</th></tr></thead><tbody><tr><td> </td><td> </td><td> </td></tr><tr><td> </td><td> </td><td> </td></tr><tr><td> </td><td> </td><td> </td></tr><tr><td> </td><td> </td><td> </td></tr><tr><td> </td><td> </td><td> </td></tr><tr><td> </td><td> </td><td> </td></tr></tbody></table>	NO.	DESCRIPTION	DATE																			 DRAWN BY: [blank] CHECKED BY: [blank] DATE: [blank] <b>B-860</b>
NO.	DESCRIPTION	DATE																						

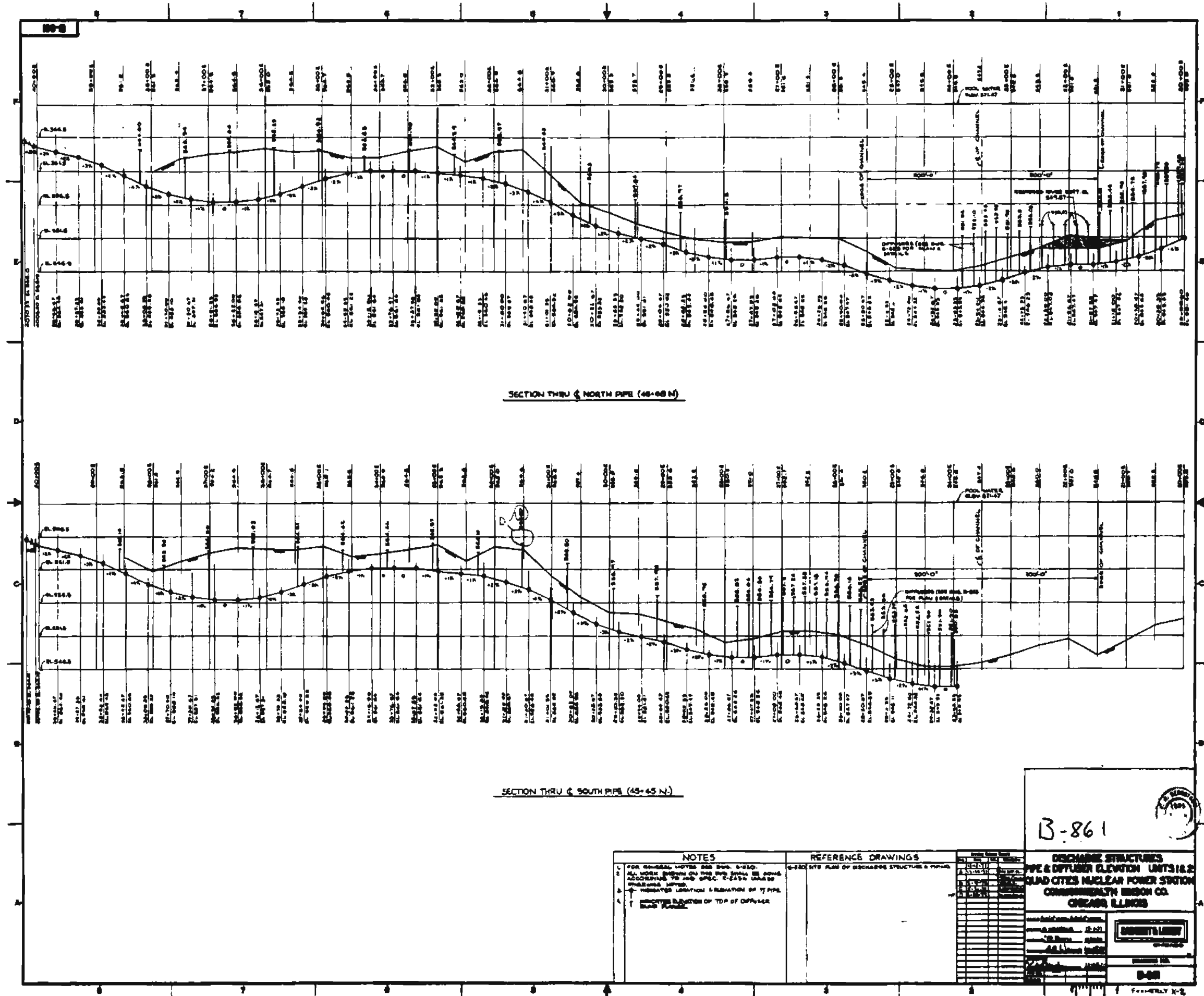

SECTION THRU NORTH PIPE (48-68 N)

SECTION THRU SOUTH PIPE (48-68 S)

**NOTES**

- FOR GENERAL NOTES SEE SHEET 48-68.
- ALL WORK SHOWN ON THIS SHEET IS TO BE ACCORDING TO THE JUNE 1964 EDITION OF THE DESIGN MANUAL.
- INDICATED LOCATION & ELEVATION OF PIPE HEAD.
- INDICATED LOCATION OF TOP OF DIFFUSER HEAD.

**REFERENCE DRAWINGS**

48-68 SITE PLAN OF DISCHARGE STRUCTURE & PIPING

NO.	DESCRIPTION	DATE
1	48-68	1964
2	48-68	1964
3	48-68	1964
4	48-68	1964
5	48-68	1964
6	48-68	1964
7	48-68	1964
8	48-68	1964
9	48-68	1964
10	48-68	1964

B-861



DISCHARGE STRUCTURES  
PIPE & DIFFUSER ELEVATION UNITS 1&2  
DUAL CITIES NUCLEAR POWER STATION  
COMMERCIAL UNION CO.  
CREASER, ILLINOIS

CREASER ENGINEERS

CREASER ENGINEERS  
1000 N. WASHINGTON ST.  
CHICAGO, ILL. 60610  
TELEPHONE: 312-467-1100  
FAX: 312-467-1101

B-861

FORM 100-1  
F-100-1-1-1

## **Exhibit 29**

Evaluation of the Quad Cities Nuclear Generating Station  
Diffuser Pipe System At Low River Flows

**EVALUATION OF THE QUAD CITIES  
NUCLEAR GENERATING STATION  
DIFFUSER PIPE SYSTEM  
AT LOW RIVER FLOWS**

by  
Subhash C. Jain and John F. Kennedy

Submitted to  
Commonwealth Edison Company  
Chicago, Illinois

IIHR Limited Distribution Report No. 174

Iowa Institute of Hydraulic Research  
The University of Iowa  
Iowa City, Iowa 52242-1585

July 1990



**ACKNOWLEDGEMENTS**

This study was sponsored by the Commonwealth Edison Company (CECO), Chicago, Illinois. The authors express their appreciations to Mr. Jeffrey P. Smith and Ms. Julia Wozniak of CECO for their indispensable assistance throughout the course of this study.

Drs. W.F. Krajewski and H.R. Bravo of Iowa Institute of Hydraulic Research (IIHR) assisted the authors in conducting the study described in Part Three of the report. Mr. C.C. Wang, Graduate Research Assistant at IIHR, helped in processing the field data.

**TABLE OF CONTENTS**

	<u>Page</u>
LIST OF TABLES.....	iv
LIST OF FIGURES.....	v
FOREWORD.....	vi
EXECUTIVE SUMMARY.....	ix
<b><u>PART ONE: ANALYSIS OF THE DIFFUSER-PIPE SYSTEM.....</u></b>	<b>1</b>
I. INTRODUCTION.....	1
II. ANALYTICAL MODEL.....	4
III. FIELD DATA.....	11
IV. DIFFUSER PERFORMANCE.....	15
A. Permissible Load Factor.....	19
B. Method for Monitoring Plume.....	22
V. OPTIMUM DIFFUSER CONFIGURATION.....	23
VI. SUMMARY AND CONCLUSIONS.....	26
REFERENCES.....	28
<b><u>PART TWO: ANALYSIS OF COOLING POTENTIAL OF THE COOLING CANAL..</u></b>	<b>29</b>
I. INTRODUCTION.....	29
II. ANALYTICAL MODEL.....	29
III. COOLING POTENTIAL OF COOLING CANAL.....	32
IV. CONCLUSIONS.....	34
REFERENCES.....	37
<b><u>PART THREE: TREND ANALYSIS TO THE MISSISSIPPI RIVER FLOW</u></b>	
REGIME.....	38
I. INTRODUCTION.....	38
II. PRELIMINARY DATA ANALYSIS.....	38

III. THE TEST ..... 43  
IV. APPLICATION OF THE TEST ..... 45  
V. CONCLUSIONS ..... 46  
  
REFERENCES ..... 46

LIST OF TABLES

	<u>Page</u>
<b><u>PART ONE</u></b>	
1. River Flow and Plant Effluent Data.....	13
2. Maximum Local Excess Temperature.....	20
3. Second Highest Local Excess Temperature.....	27
 <b><u>PART THREE</u></b>	
4. Auto Correlations of Discharges and Temperatures for the Same Month.....	41

LIST OF FIGURES

<u>PART ONE</u>	<u>Page</u>
1. Existing diffuser-pipe system.....	2
2. Existing temperature monitoring curve. ....	3
3. Schematic for one-dimensional analysis of a multiport diffuser. ....	5
4. Variation of discharge ratio with normalized diffuser length and jet area.....	8
5. Schematics of flow configurations developed by multiple diffuser. a) $R < R_0$ ; b) $R > R_0$ . ....	9
6. Idealized cross section of the river. ....	10
7. Locations of the measurements sections.....	12
8. Normalized transverse discharge distributions in the upstream section.....	14
9. Normalized transverse discharge distributions in the downstream section.....	16
10. Temperature distributions in the downstream section.....	17
11. Modified temperature monitoring curves.....	21
12. Temperature-rise distributions in the downstream section.....	24
13. Normalized transverse distributions of heat flux in the downstream section.....	25
 <u>PART TWO</u>	
14. Plan view of the QCNGS cooling canal.....	30
15. Schematic for one-dimensional plug-flow analysis of a cooling canal.....	31
16. Cooling-canal discharge.....	33
17. Flow-duration curve for the Mississippi River at Clinton, Iowa (1 Oct. 1937- 30 Sept. 1987).....	35
18. Additional electric energy per year generated by using the cooling canal.....	36
 <u>PART THREE</u>	
19. Monthly discharge of the Mississippi River at Clinton, Iowa.....	39
20. Monthly water temperature of the Mississippi River at Clinton, Iowa.....	40
21. Autocorrelation function of the monthly discharge data of the Mississippi River at Clinton, Iowa. ....	42

**EVALUATION OF THE QUAD CITIES NUCLEAR GENERATING STATION DIFFUSER PIPE SYSTEM AT LOW RIVER FLOWS**

**FOREWORD**

The Quad Cities Nuclear Generating Station (QCNGS) of the Commonwealth Edison Company (CECO), which is located on the east bank of the Mississippi River about 3 miles north of Cordova, Illinois, utilizes a diffuser-pipe system to distribute its condenser-water discharge across the river. The diffuser-pipe system consists of two pipes buried in the river bed; each pipe is fitted with a number of discharge risers through which the condenser water is discharged across the river. The diffuser-pipe system was designed to achieve complete mixing of the condenser water with the river flow within a short distance downstream of the diffuser pipes. The design was based on the results of physical model studies conducted at Iowa Institute of Hydraulic Research (IIHR) and reported by Jain et al. (1971). At the time the diffuser-pipe system was designed, no field data were available on the low-discharge river-flow distribution across the channel to guide calibration of the model. Moreover, because of space and time limitations on the model and conduct of the model study, a very small model was used in the study of the three-dimensional mixing of the diffuser pipe. In recognition of possible future needs to "fine tune" the diffuser-pipe system, the risers were fitted with replaceable orifice plates at their ends; and extra, blind-flanged risers were installed on the diffuser pipe.

According to NPDES Permit No. IL 0005037, the condenser-water discharge from the QCNGS diffuser system must comply with the following thermal standards at the edge of the mixing zone:

- A. Maximum temperature rise above natural temperature must not exceed 5°F.
- B. Water temperature at representative locations in the main river shall not exceed the maximum limits in the following table during more than one (1) percent of the hours in the 12-month period ending with any month. Moreover, at no time shall the water temperature at such locations exceed the maximum limits in the following table by more than 3°F. (Main river temperatures are temperatures of those portions of the river essentially similar to and following the same thermal regime as the temperatures of the main flow of the river.)

<u>Jan.</u>	<u>Feb.</u>	<u>Mar.</u>	<u>Apr.</u>	<u>May</u>	<u>June</u>	<u>July</u>	<u>Aug.</u>	<u>Sept.</u>	<u>Oct.</u>	<u>Nov.</u>	<u>Dec.</u>
45	45	57	68	78	85	86	86	85	75	65	52°F

- C. The area of diffusion of an effluent in the receiving water is a mixing zone, and that mixing zone shall not extend:
- i) over more than 25 percent of the cross sectional area or volume of flow in the Mississippi River;
  - ii) more than 26 acres of the Mississippi River.

River discharge, ambient river temperature, and plant load data indicating compliance with the above temperature limitations will be accepted as evidence of compliance in lieu of actual determination of the 5°F temperature-rise isotherm by plotting river discharge and plant load on the temperature monitoring curve<sup>1</sup>. If ambient river temperatures are within 5°F of the limiting temperatures for each month, temperature surveys at the 500 ft. downstream cross section are required once per week only when the river discharge is less than the minimum value for which compliance has been verified by temperature surveys in the field. At present this minimum river discharge is 16,000 cfs.

A simple thermal energy balance indicates that a diffuser-pipe system capable of achieving perfect mixing would satisfy the thermal standard A at full plant load for river discharges higher than about 9,640 cfs. However, the existing temperature monitoring curve, which is based on the actual performance of the diffuser system in the field, shows that the minimum river discharge required to satisfy the thermal standards at the full-plant load is about 16,000 cfs. The large difference between the actual and theoretical values of the minimum river discharge for compliance with thermal standards is a result of the diffuser-pipe system, as presently configured, failing to achieve complete mixing of the river flow and diffuser effluent. The drought of 1988 and 1989 produced several periods of river flow less than 16,000 cfs during the high-electricity-demand summer months, and necessitated the derating of QCNGS to comply with the thermal standards. This low-flow restraint on plant load could be relaxed by improving the mixing performance of the diffuser-pipe system.

In addition to the diffuser-pipe system, QCNGS was fitted with a closed-cycle cooling canal. This canal was, at one time, equipped with spray modules and was used as the sole cooling system for the plant. Although the spray modules since have been removed, the canal could be used as a small cooling pond to augment the diffuser-pipe system.

---

<sup>1</sup> The temperature monitoring curve is shown on p. 83 of the March 16, 1981 "Supplement to 316(a) and 316(b) Demonstration For the Quad Cities Nuclear Generating Station."

Some evidence suggests that the 1988-9 drought and heat waves may not have been isolated natural events, but an early consequence of the "greenhouse effect". Accordingly, it is of interest to find out if there are identifiable trends in the time series of water discharge and temperature of the river, which can be of future use in managing the waste heat from QCNGS.

It was against this background that CECO engaged IIHR to undertake an investigation to develop strategies and the associated designs to enable QCNGS to operate at full load during periods of Mississippi River low flow and to identify short-term trends in the river-water discharge and temperature data. The investigation was conducted in the following steps:

1. Development of an optimum configuration of the diffuser-pipe system by evaluating and analyzing the QCNGS thermal-plume data that have been collected by IIHR. Emphasis was placed on data obtained at lower river discharges.
2. Development of improved, yet simpler, methods for monitoring the plume, for use in operation of the station so as to be in compliance with the thermal standards.
3. Development of new permissible load-factor criteria for the station.
4. Evaluation of the cooling potential of the cooling canal, if it could be placed back into operation.
5. Trend analysis of the river-water discharge and temperature data.

The investigation was conducted in three parts. Part One of the present report was concerned primarily with evaluation of the performance, and the optimization, of the diffuser-pipe system. Part Two analyzes the cooling potential of the cooling canal. The trend analysis of the river-water discharge and temperature data are described in Part Three of this report.



## EXECUTIVE SUMMARY

An investigation was undertaken to develop strategies and associated diffuser-pipe modifications to enable the Quad Cities Nuclear Generating Station to operate at full load during periods of low Mississippi River flow. The investigation was conducted in three major phases: development of an optimum configuration of the diffuser-pipe systems by analyzing the QCNGS thermal-plume data; evaluation of the cooling potential of the cooling canal; and trend analysis of the river-water discharge and temperature data.

The summary and conclusions of this investigation are as follow:

- (1) A one-dimensional analytical model, and field data from eight surveys during the summers of 1988 and 1989, when the river discharges were unusually low, were used to evaluate the performance of, and to optimize, the existing QCNGS diffuser-pipe system. The results of the analytical model were in agreement with the field data. The overall mixing of the condenser-water discharge with the ambient flow in surveys with discharge ratio less than the critical discharge ratio ( $R < R_0$ , defined on page 7), was almost uniform, except for local "hot spots" and "cold spots" which occurred, respectively, due to relative deficiency, and excess of dilution water. A modified temperature-monitoring curve, TMC-1, based on the field data and a simple procedure for monitoring the thermal plume were developed.
- (2) The performance of the diffuser system could be improved by reducing the condenser-water discharge near the Iowa shore and increasing it in the deeper portion of the river section. Another modified temperature monitoring curve, TMC-2, based on the modified distribution of the condenser-water discharge was developed. For TMC-2, the minimum river discharge to comply the thermal standards at full load is about 11,000 cfs. A physical model study of the diffuser system is recommended to determine the optimum distribution of the condenser-water discharge.
- (3) The cooling potential of the cooling canal was evaluated by using a one-dimensional plug-flow model. The cooling canal could be used to cool only about 0.9 to 2.2 percent of the maximum condenser-water

discharge. The cooling canal would be beneficial adjunct to the optimum diffuser configuration and could be used for river flows less than about 11,000 cfs; such flows occur only about 0.16 percent of the time. The additional electric power that could be generated by the use of the cooling canal is about 8 to 19 MW-day per year.

- (4) A nonparametric trend test was used to analyze trends in the discharge and temperature data for the Mississippi River at Clinton, Iowa. Neither long-term nor short term trends were detected in the data.

## PART ONE

### ANALYSIS OF THE DIFFUSER-PIPE SYSTEM

#### I. INTRODUCTION

The existing diffuser-pipe system for QCNGS is shown in figure 1. It consists of two 16-foot diameter pipes buried in the river bed; one pipe extends practically across the river, while the second pipe terminates about 390 ft before the terminus of the other pipe. Each pipe is fitted with 20 discharge risers of 36 in. diameter spaced at 19 ft 8 in. in the deep portion of the river and 14 discharge risers (9 of which are presently closed) of 24 in. diameter spaced 78 ft 8 in. intervals in the shallow zone of the river. Each discharge riser is equipped with a removable orifice plate at its discharge end; the orifice diameter is 0.9 of that of the riser. The maximum condenser-water discharge and temperature rise are 2094 cfs and 23° F, respectively.

The existing temperature monitoring curve (TMC) is presented in figure 2, which also includes the perfect mixing curve for the maximum condenser-water discharge of 2094 cfs and the maximum condenser-water temperature rise of 23° F (Commonwealth Edison 1981).  $(T - T_a)_{\max}$  and P/100 in the ordinate are the maximum temperature rise above natural temperature and the fractional plant load which ranges from zero at no load to one at full load, respectively. In order that  $(T - T_a)_{\max}$  not exceed 5° F at full load, river discharges larger than about 9,640 cfs and 16,000 cfs are required according to the perfect-mixing curve and the existing TMC, respectively. The large difference between the two river discharges indicates that the present diffuser system configuration does not achieve uniform mixing of the condenser-water with the river flow.

To monitor the performance of the diffuser, IIHR has been collecting the QCNGS thermal plume data since the early 1970's, including the summers of 1988 and 1989 when Mississippi River discharges were unusually low.

In this Part of the report, the QCNGS thermal-plume data at low river flows are evaluated and analyzed to develop an optimum configuration of the diffuser-pipe system. An analytical model which was used to evaluate the performance of, and to optimize, the QCNGS diffuser-pipe system is described. A new permissible load-factor criterion for the station, and a simpler method for monitoring the plume for use in operation of the station so as to be in compliance with the thermal standards, are presented.

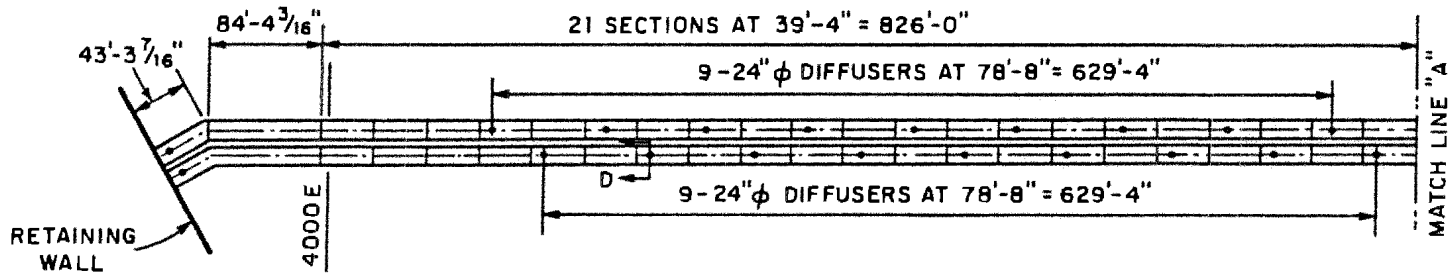

DIFFUSER PIPES - TOP PLAN

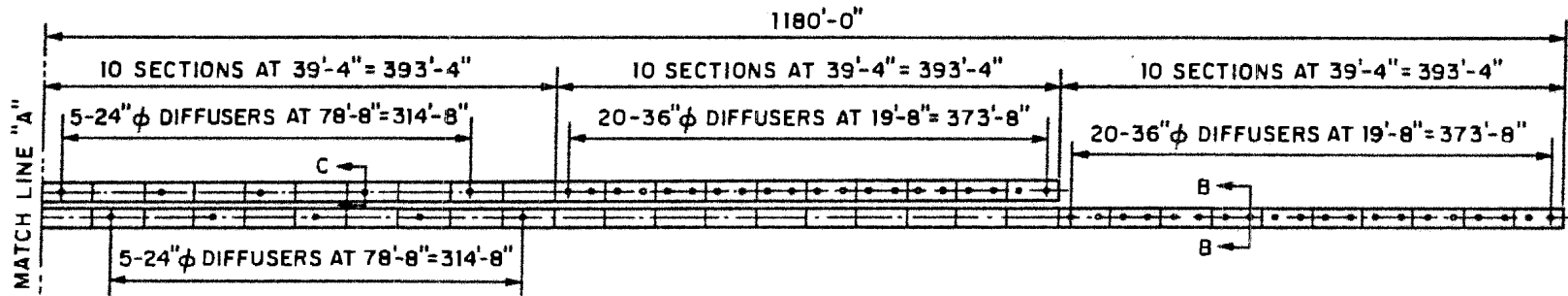

DIFFUSER PIPES - TOP PLAN

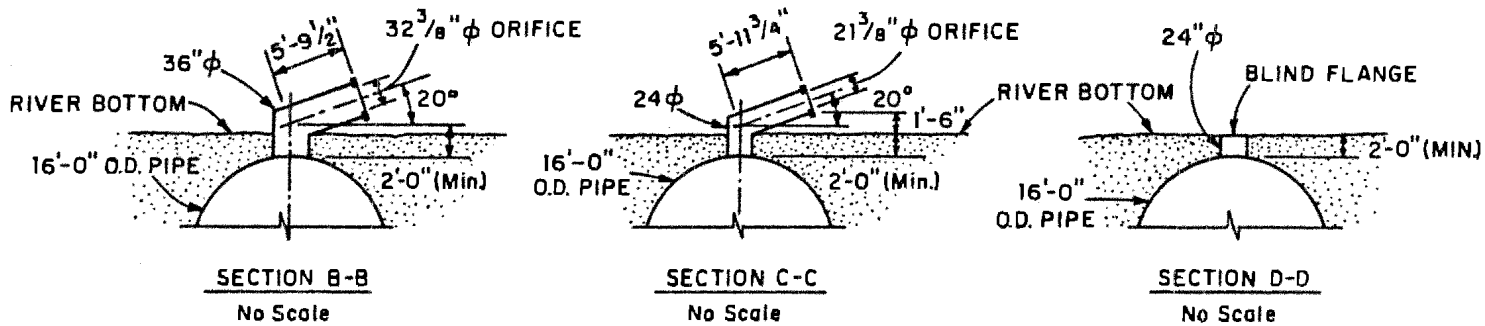

Figure 1. Existing diffuser-pipe system.

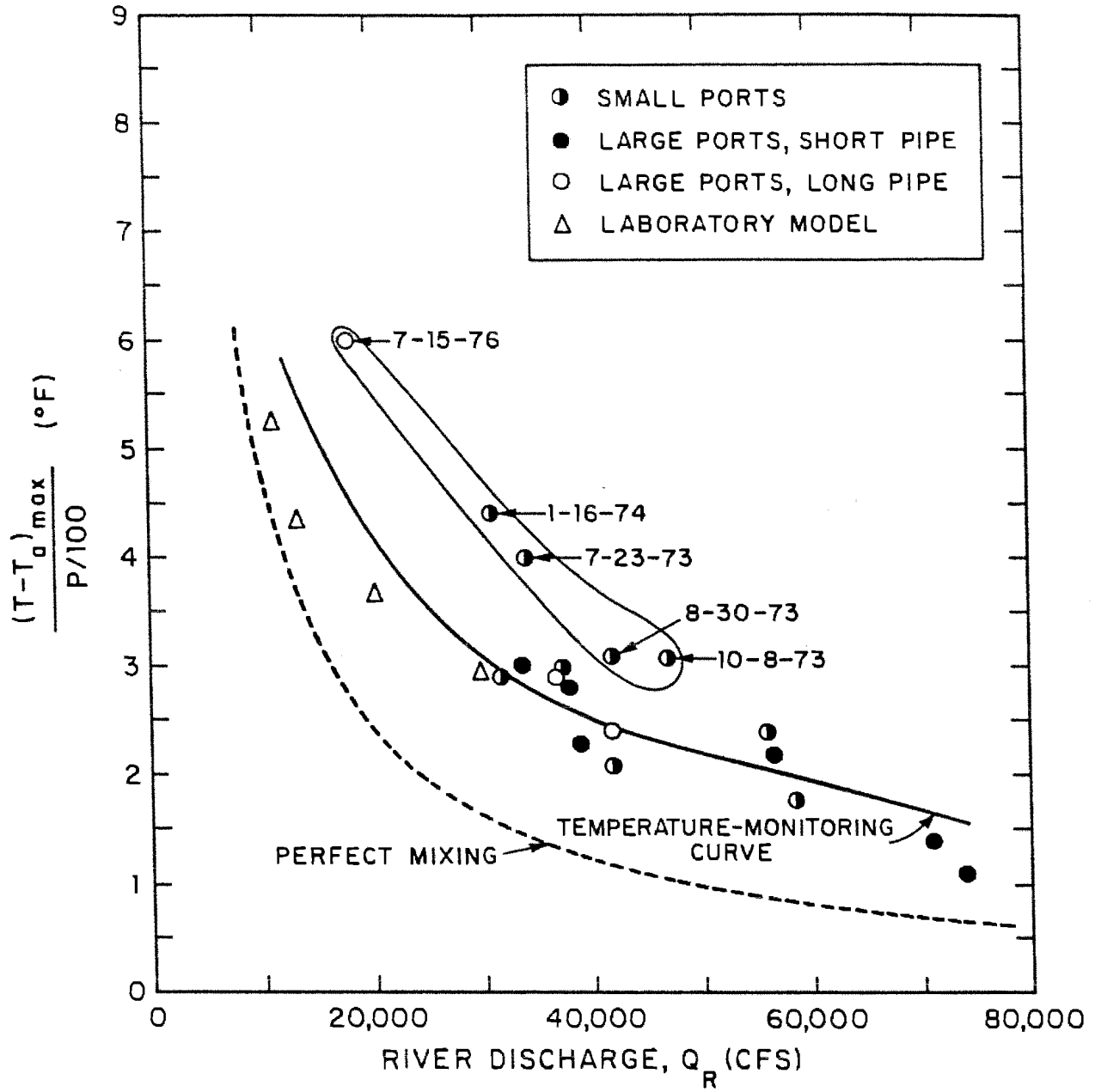

Figure 2. Existing temperature monitoring curve.

## II. ANALYTICAL MODEL

A one-dimensional analytical model was developed to determine the parameters that characterize the temperature-rise characteristics of a thermal plume produced by heated water discharge from a multiport diffuser into a river. The model was used to evaluate the performance of, and to optimize, the QCNGS diffuser-pipe system.

A schematic of the one-dimensional analysis of a multiport diffuser is shown in figure 3. The analytical strategy is analogous to that for propeller thrust. The river cross-section is idealized as a rectangular section. The diffuser discharge is represented by a series of  $n$  jets with spacing  $\ell$  and discharging with a horizontal velocity  $U_0$ . The flux of momentum from the diffuser jets into the receiving water accelerates a part of the river flow and draws it over the diffuser, as shown in the top view in figure 3. The momentum flux from the jets accelerates the flow just upstream from the diffuser, thereby lowering the water surface. Just downstream from the diffuser, the momentum flux is transformed into a pressure rise, which is manifested by an increase in the water-surface elevation. The river water mixes with the jet effluent as it passes over the diffuser. The flow field continues to contract due to its inertia until Section 4, where the flow depth  $H_4$  is the same as the flow depth  $H_1$  at Section 1; i.e.,  $H_1 = H_4 = H$ . The region from which ambient flow is drawn over the diffuser is delineated by the dividing streamlines in the plan view in figure 3.

The governing equations for the control volume bounded by dividing streamlines are the following.

Continuity Equations:

Between sections 1 and 2,

$$u_1 \ell_1 H_1 = u_2 \ell_2 H_2 \quad (1)$$

Between sections 2 and 3

$$u_2 \ell_2 H_2 + Q_d = u_3 \ell_3 H_3 \quad (2)$$

Between sections 3 and 4

$$u_3 \ell_3 H_3 = u_4 \ell_4 H_4 \quad (3)$$

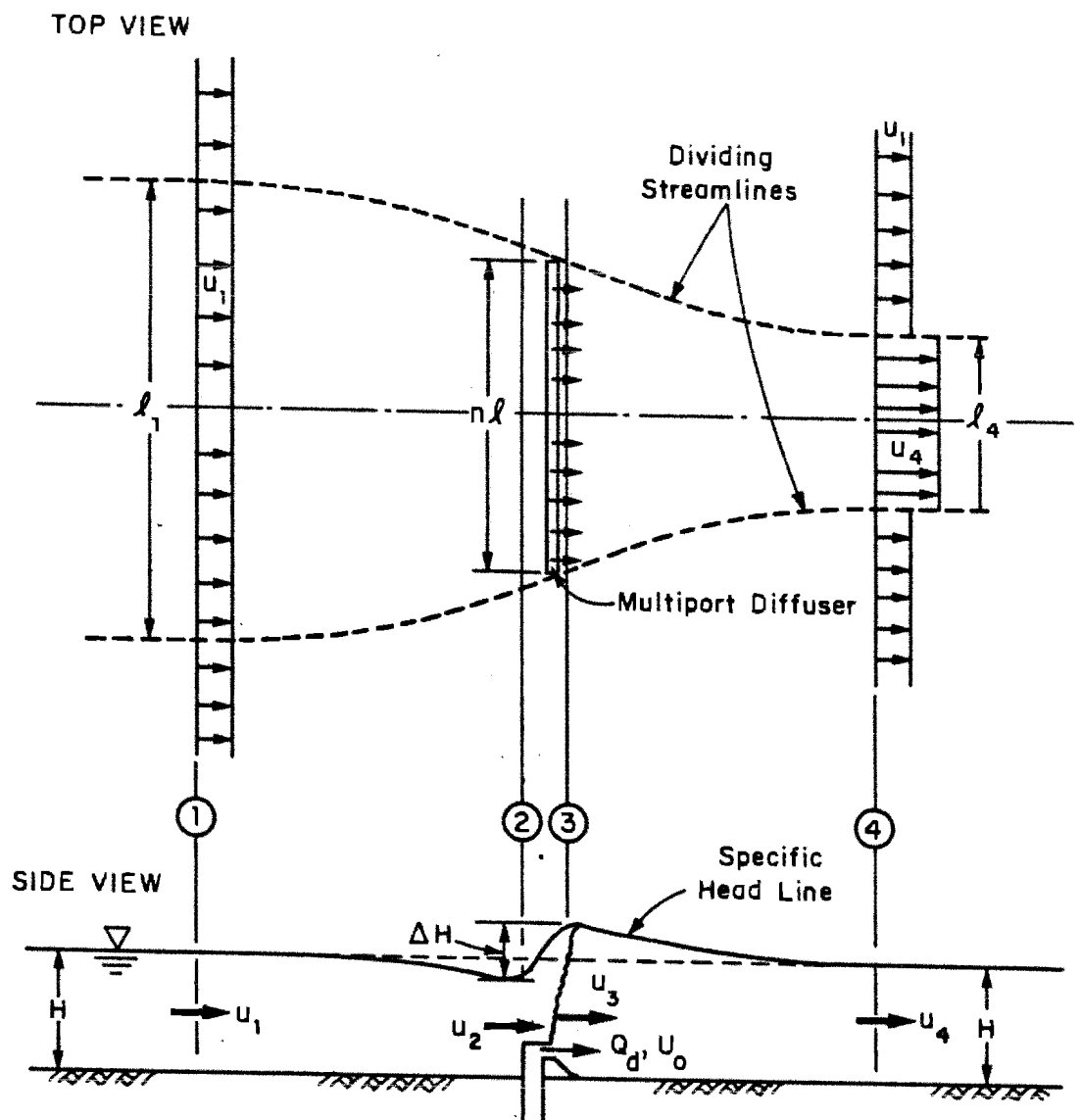

Figure 3. Schematic for one-dimensional analysis of a multiport diffuser.

Energy Equations:

Between sections 1 and 2

$$H_1 + \frac{u_1^2}{2g} = H_2 + \frac{u_2^2}{2g} \quad (4)$$

Between sections 3 and 4

$$H_3 + \frac{u_3^2}{2g} = H_4 + \frac{u_4^2}{2g} \quad (5)$$

Momentum Equations:

Between sections 2 and 3

$$\frac{\rho g n \ell}{2} (H_2^2 - H_3^2) = \rho (u_3^2 \ell_3 H_3 - Q_d U_o - u_2^2 \ell_2 H_2) \quad (6)$$

Between sections 1 and 4

$$\rho (u_4^2 \ell_4 H_4 - u_1^2 \ell_1 H_1 - Q_d U_o) = 0 \quad (7)$$

in which  $H_i$  = flow depth at section  $i$ ;  $u_i$  = flow velocity at section  $i$ ;  $Q_d$  = diffuser discharge;  $U_o$  = horizontal component of diffuser jet velocity;  $\ell_i$  = channel width between dividing streamlines at section  $i$ ;  $\rho$  = density of water; and  $g$  = gravitational acceleration. The friction along the lateral dividing streamlines and the river bottom, and the change in water density with water temperature have been neglected in the analysis. Sections 2 and 3 are close to the diffuser section, so  $\ell_2 = \ell_3 = n\ell$ . Furthermore, because the change in flow depth is very small (less than about one percent),  $H_1$ ,  $H_2$ ,  $H_3$  and  $H_4$  in Eqs. 1, 2, and 3 are assumed to be equal to  $H$ . The horizontal component of jet diffuser velocity can be written in terms of diffuser discharge and total jet area as

$$U_o = \frac{Q_d}{A_o} \cos \theta \quad (8)$$

in which  $A_o$  = total jet area; and  $\theta$  = jet angle with the horizontal. Eqs. 1 through 8 yield



$$2A^2(L^2 - 1)R^3 + (5A^2L^2 - 2AL + 2A - A^2)R^2 - 4AL(1 - AL)R + (1 - AL)^2 = 0 \quad (9)$$

in which  $L = \frac{\ell_1}{\ell_d}$ ;  $\ell_d = n\ell =$  diffuser length;  $R = \frac{u_1 \ell_1 H}{Q_d}$ ; and  $A = \frac{A_0}{\ell_1 H \cos \theta}$ . Note that  $R$ , termed discharge ratio, is the ratio of the ambient flow discharge within the width  $\ell_1$  to the diffuser discharge. The solution of Eq. 9 gives the discharge ratio,  $R$ , required to draw the ambient flow from the normalized width,  $L$ , over a diffuser with a normalized jet area,  $A$ . The variation of  $R$  with  $L$  for three values of  $A$  is presented in figure 4, which shows that  $R$  increases with decreasing  $L$  and  $A$ . If the river width happens to be equal to  $\ell_1$ , the entire river flow is drawn over the diffuser and mixed with the effluent. Therefore, for a given diffuser system (i.e., given  $A_0$ ,  $\ell_d$ , and  $\theta$ ) and flow area of the river (i.e.,  $H$  and  $B =$  river width), there exists a discharge ratio at which the entire ambient flow is mixed with the effluent; i.e.,  $B = \ell_1$ . This discharge ratio is termed critical discharge ratio and is denoted by  $R_0$ . For discharge ratios larger than  $R_0$ , the diffuser discharge is unable to draw the entire ambient flow, as shown in figure 5a; then the mixing of the effluent with the ambient flow is incomplete. The larger the discharge ratio, the smaller is the percentage of ambient flow entrained by the diffuser. On the other hand, for discharge ratios smaller than  $R_0$ , the diffuser is able to draw more flow than the available ambient flow; the effluent then is recirculated within the diffuser jets leading to the formation of a horizontal eddy near the ends of the diffuser and vertical eddies around each jet, as schematically shown in figure 5b. The smaller the discharge ratio, the larger is the recirculation and the more intense is the mixing of the ambient flow with the effluent. As shown in figure 5, the current directions in a portion of a downstream section differ from the main-flow direction due to the horizontal-eddy formation by flow recirculation and/or the expansion of the dividing streamlines.

The one-dimensional analytical model applies to a diffuser that discharges uniformly along its length in a rectangular channel. The application of this model to the QCNGS diffuser system required idealization of the geometries of the river cross sections and the diffuser. The river cross-sections were idealized by a rectangular section of 1400 ft in width and 21.4 ft in depth, as shown in figure 6. The flow depth at low river flows in this reach of the river is maintained almost constant by a downstream navigation dam. The effluent discharge per unit length of diffuser is different for the two portions of the diffuser (see Figure 1). The 393.3-foot-long portion of the diffuser with smaller ports at larger spacing, which is located in the shallow area of the river, discharges only about 10 percent of the total effluent; the remaining 90 percent effluent is discharged through the 786.7-foot-long portion of the diffuser in the deeper section of the river. The former portion of the diffuser was idealized by a 87.8-foot long diffuser with a unit discharge equal to that of the latter portion. The total idealized length of the diffuser is  $\ell_d = 874.5$  ft. The determination

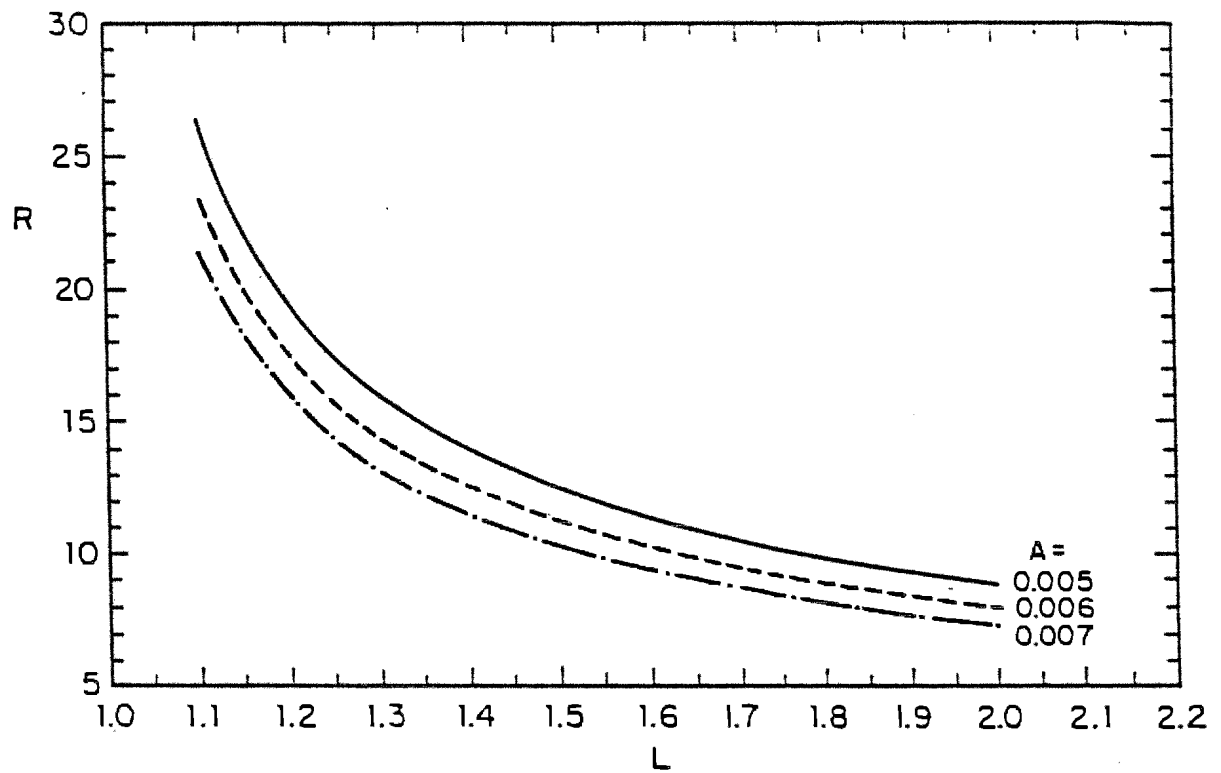

Figure 4. Variation of discharge ratio with normalized diffuser length and jet area.

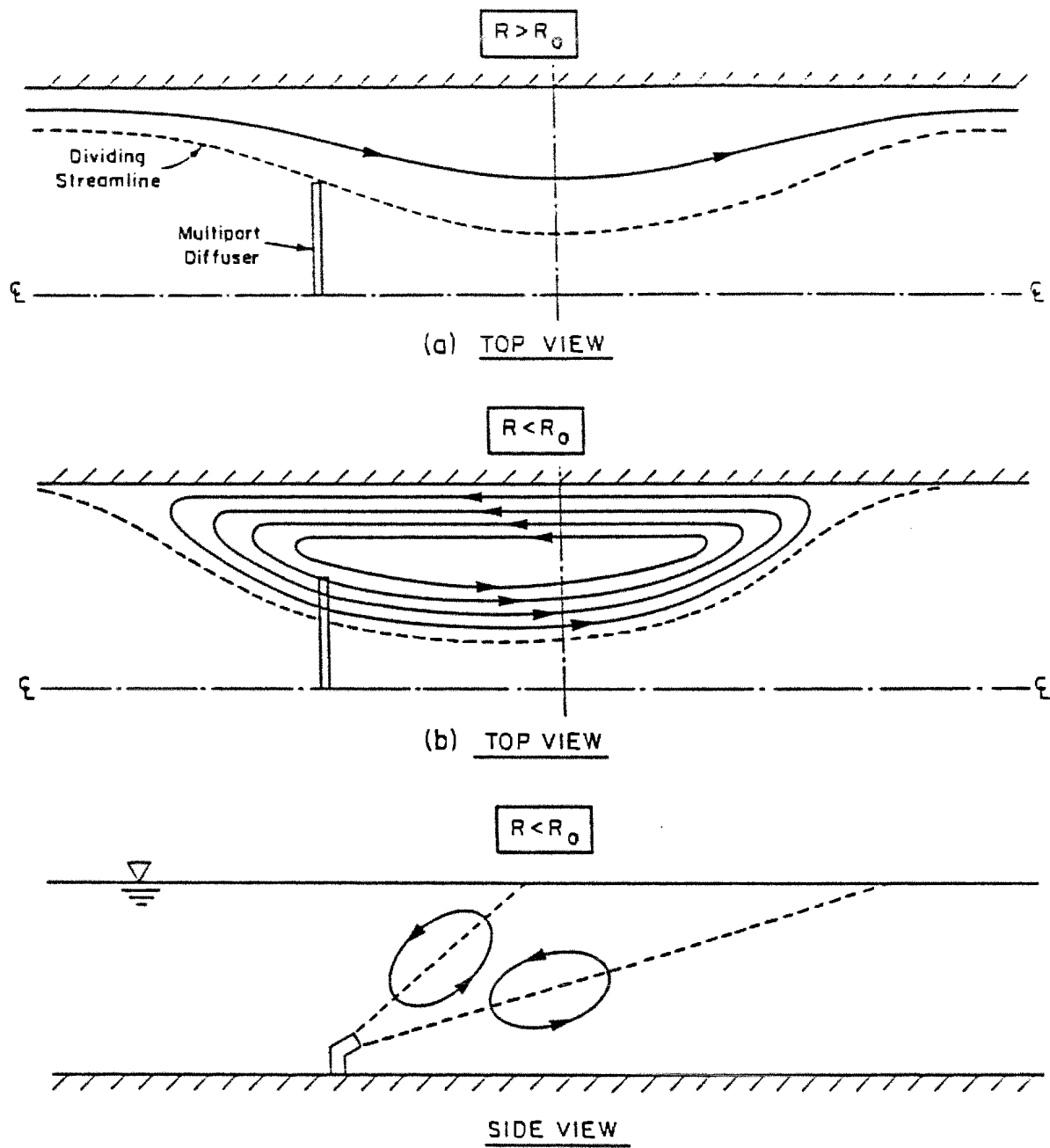

Figure 5. Schematics of flow configurations developed by multiple diffusers. a)  $R < R_0$ ; b)  $R > R_0$ .

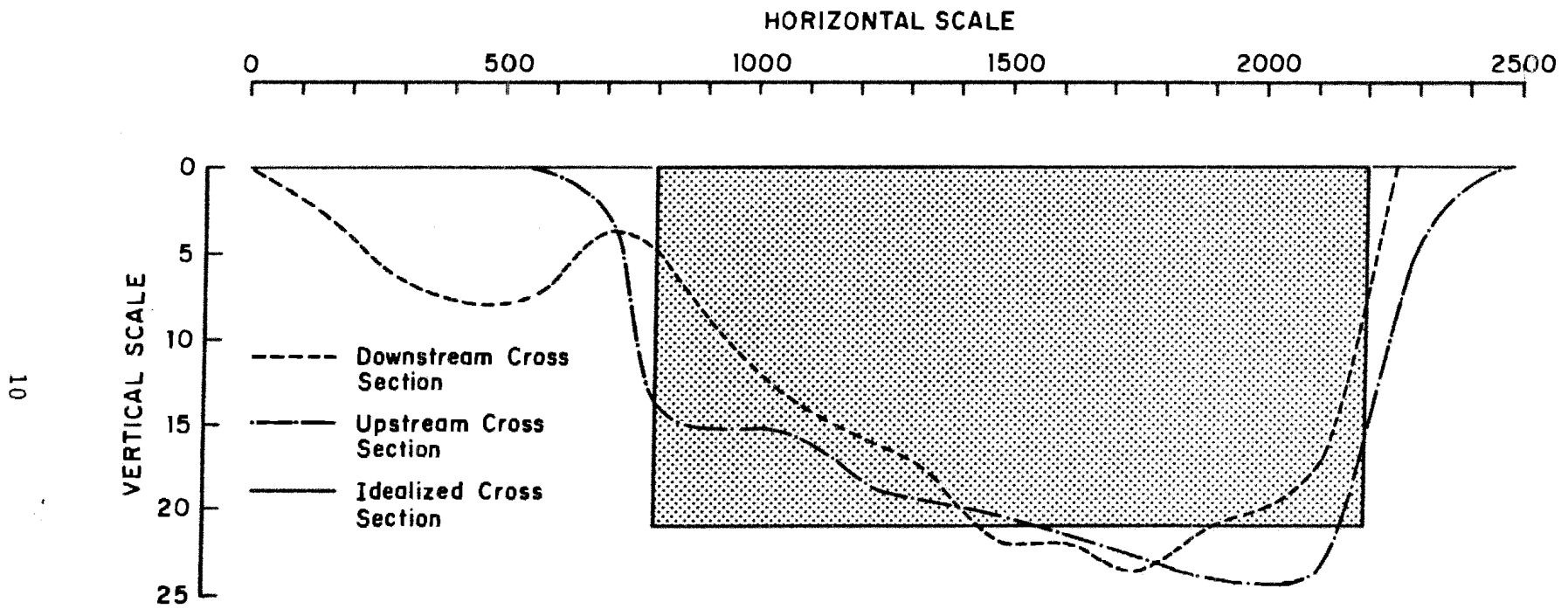

Figure 6. Idealized cross section of the river.

of the total jet area from the total orifice area required an estimate of the coefficient of contraction for the orifices, which was estimated from the results of the hydraulic model study (Jain et al. 1971) to be about 0.78. The total jet area for the present diffuser is  $A_o = 198 \text{ ft}^2$ . The critical discharge ratio for the idealized diffuser ( $A_o = 198 \text{ ft}^2$ ;  $L_d = 874.5 \text{ ft}$ ;  $\theta = 20^\circ$ ;  $B = 1400 \text{ ft}$ ; and  $H = 21.4 \text{ ft}$ ) given by Eq. 9 is 9.3. According to this analysis, the diffuser should produce complete mixing of the effluent with the ambient flow for discharge ratios smaller than 9.3, and incomplete mixing for larger discharge ratios. The field data, which are included in the ensuing section, corroborate this result.

### III. FIELD DATA

Mississippi River discharges were unusually low in the summers of 1988 and 1989. Field data collected during this period were used to evaluate the performance of the diffuser. The field data included velocity and temperature measurements across the two river cross-sections shown in figure 7, located 1000 ft upstream and 500 ft downstream of the diffuser. Eight field surveys were conducted during these summers. A summary of the field data is presented in table 1. The river discharges (published by USGS) at Clinton, Iowa, which is about 12 miles upstream of QCNGS, also are included in the table. The effluent temperature rises for surveys 5 and 6 in August 88 were small, because the ambient water temperature in that period was close to the maximum permissible limit of 86°F for August and therefore the station was derated.

It should be pointed out that the flows in regions near the Illinois shore, where the current directions were observed by IIHR staff to be different from the main flow direction, were not included in the river discharges in table 1. The current directions in a portion of the upstream section were different from the main flow direction due to an eddy formed by flow separation downstream of the boat ramp on the Illinois bank (see figure 7). The eddy was small and weak, and the effect of the eddy on the computations of the river discharge in the upstream section was considered small. The agreement between the river discharges measured by IIHR and USGS corroborates this assumption. The reasons for the current directions in a portion of the downstream section being different than the main flow direction are discussed above (in conjunction with figure 5).

The normalized transverse distributions of the river flow in the upstream section are shown in figure 8. The variables in the figure are:  $q$  = local river discharge per unit width;  $\bar{q} = Q_R/W$  = width-averaged value of  $q$ ;  $Q_R$  = river discharge;  $W$  = channel width; and  $z$  = distance from the Illinois shore. No significant influence of total river flows on the river-

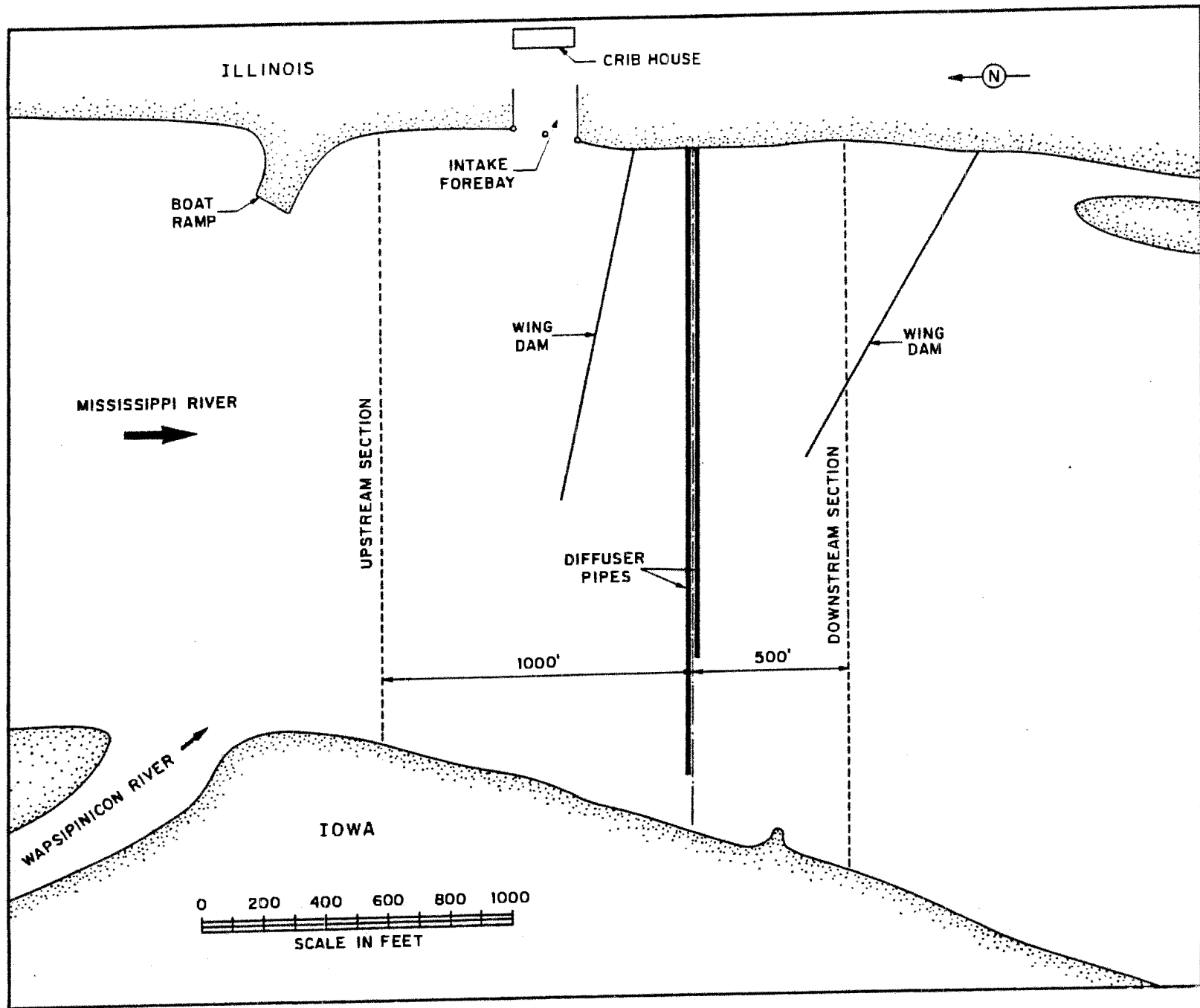

12

Figure 7. Locations of the measurements sections.

Table 1. River Flow and Plant Effluent Data

Survey No.	Date of Survey	River Discharge			Average Ambient Temperature °F	Plant Effluent $Q_d$ cfs	Effluent Temperature Rise °F	Discharge Ratio $R = \frac{(Q_R - Q_d)}{Q_d}$	Recirculation
		a	b	c					
1	6-21-88	14,400	14,200	13,700	80.3	1047	17.0	12.8	NO
2	7-5-88	11,400	10,700	15,200	79.5	2094	22.2	4.4	YES
3	7-11-88	13,600	14,400	16,900	82.0	2094	18.1	5.5	YES
4	7-28-88	14,000	14,000	11,000	82.9	1047	17.2	12.4	NO
5	8-4-88	13,600	13,000	12,000	85.6	1047	5.1	12.0	NO
6	8-11-88	16,500	15,300	18,600	83.6	1745	11.9	8.5	YES
7	8-3-89	16,600*	--	18,000	81.8	2094	21.4	6.9	YES
8	8-15-89	11,100	--	14,400	77.3	2094	20.1	4.3	YES

- a Measured by IIHR 1,000 ft upstream of the diffuser pipes  
b Reported by USGS at Clinton, Iowa  
c Measured by IIHR 500 ft downstream of the diffuser pipes  
\* Reported by Corps of Engineers at Clinton, Iowa (Odgaard, 1989)  
-- Not available

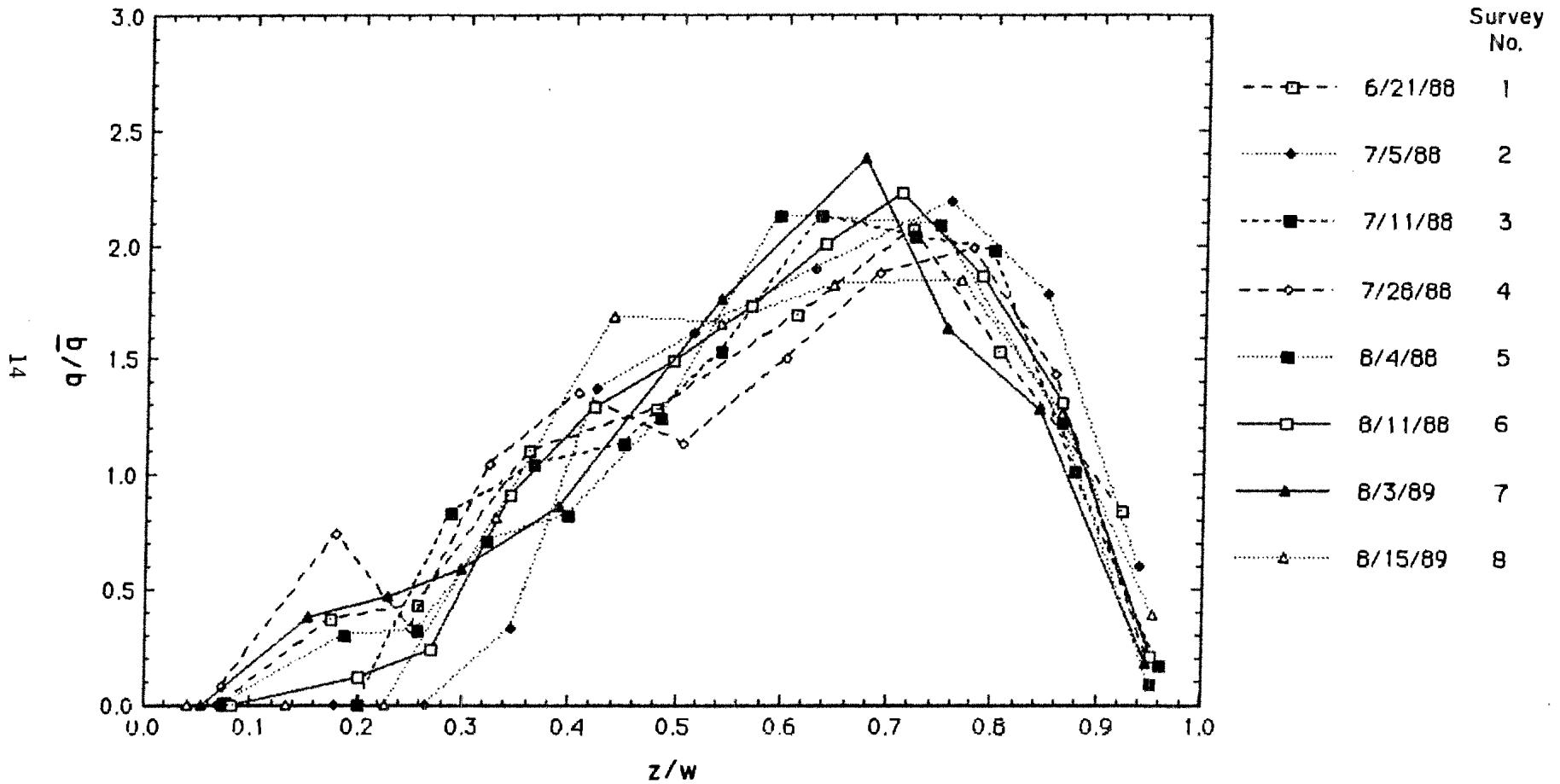

Figure 8. Normalized transverse discharge distributions in the upstream section.



flow distribution is apparent in figure 8; this indicates that the transverse flow distribution is primarily controlled by flow depth, except near the Iowa shore in some surveys where the unit discharge is high due to flows from the Wapsipinicon River. The normalized transverse distributions of the river flows in the downstream section are shown in figure 9. The effect of diffuser discharge, which acts like a jet pump, on the river-discharge distribution is evident in a comparison of figures 8 and 9; the jet action is more visible for the surveys at low discharge ratios. The temperature distributions are presented below.

#### IV. DIFFUSER PERFORMANCE

The flow behavior of a diffuser is governed primarily by the discharge ratio. In the field surveys, the discharge ratio for the present diffuser ranged from 4.4 to 12.8 (table 1). The discharge ratios for surveys 1, 4, and 5 (referred to as Group A) are larger than, and for surveys 2, 3, 6, 7 and 8 (referred to as Group B) are smaller than, the critical discharge ratio of 9.3 for the QCNGS diffuser. According to the theoretical analysis presented in Section II, complete mixing of the effluent with the ambient flow and recirculation of the effluent by the jets from the diffuser leading to the development of horizontal eddies near the diffuser ends should occur for Group B. The momentum flux imparted by the diffuser jets in Group A is not sufficient to draw the entire ambient flow and produce complete mixing of the effluent with the ambient flow. This result of the analysis is in agreement with the results of the field surveys, as the following discussion demonstrates.

The measured river discharges were different in the upstream and downstream sections (table 1). The discharges at the downstream section for Group B were higher than, and for Group A were lower than, those at the upstream section. The higher discharges at the downstream section compared to the upstream section (Group B) were due to inclusion of flow returned upstream by recirculation in the horizontal eddy observed near the Illinois bank. (The horizontal eddy near the Iowa shore was small, because the diffuser pipe extended almost to that shore.) The reason for the lower discharges in the downstream section in Group A was exclusion in computations of flow through a portion of the river near the Illinois shore where the current directions were towards the Illinois bank, due to flow expansion, as explained earlier. No flow recirculation was observed in these surveys.

The temperature distributions in the form of isotherms at the downstream section are presented in figure 10. The overall mixing characteristics of the diffuser as depicted by the isotherms are in agreement with the analytical results, except for the local "hot and cold

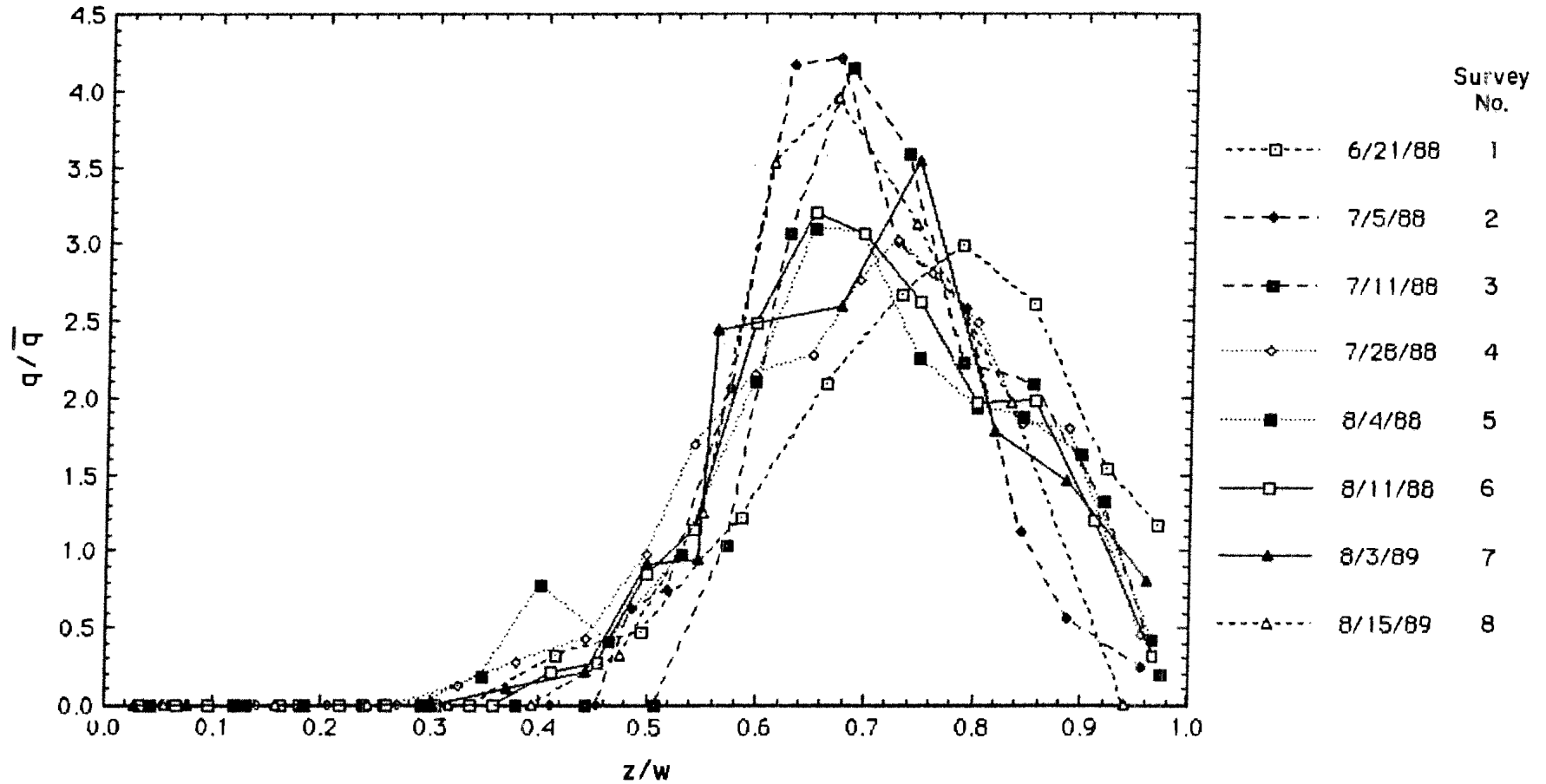

Figure 9. Normalized transverse discharge distributions in the downstream section.

17

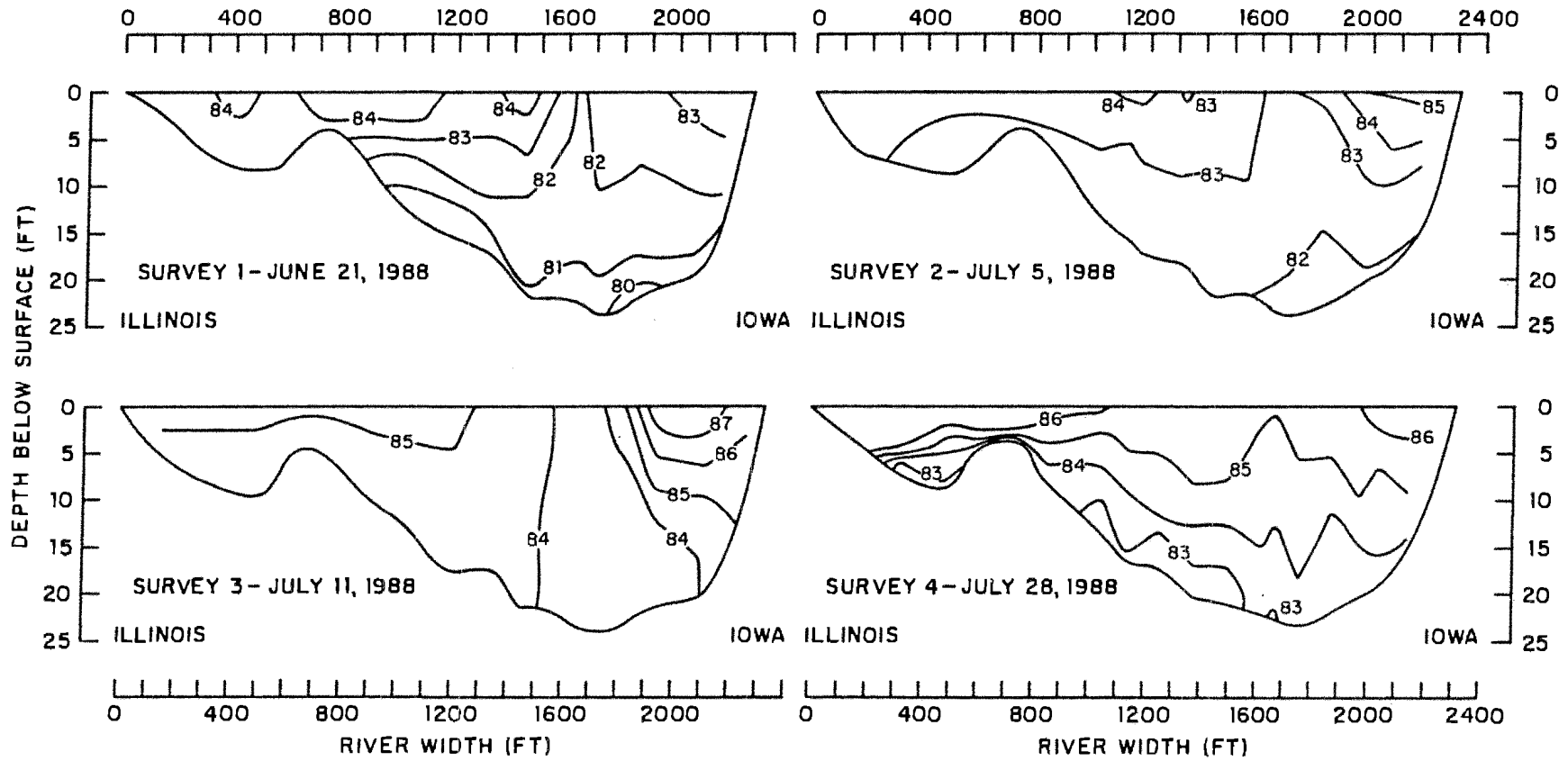

Figure 10. Temperature distributions in the downstream section.

18

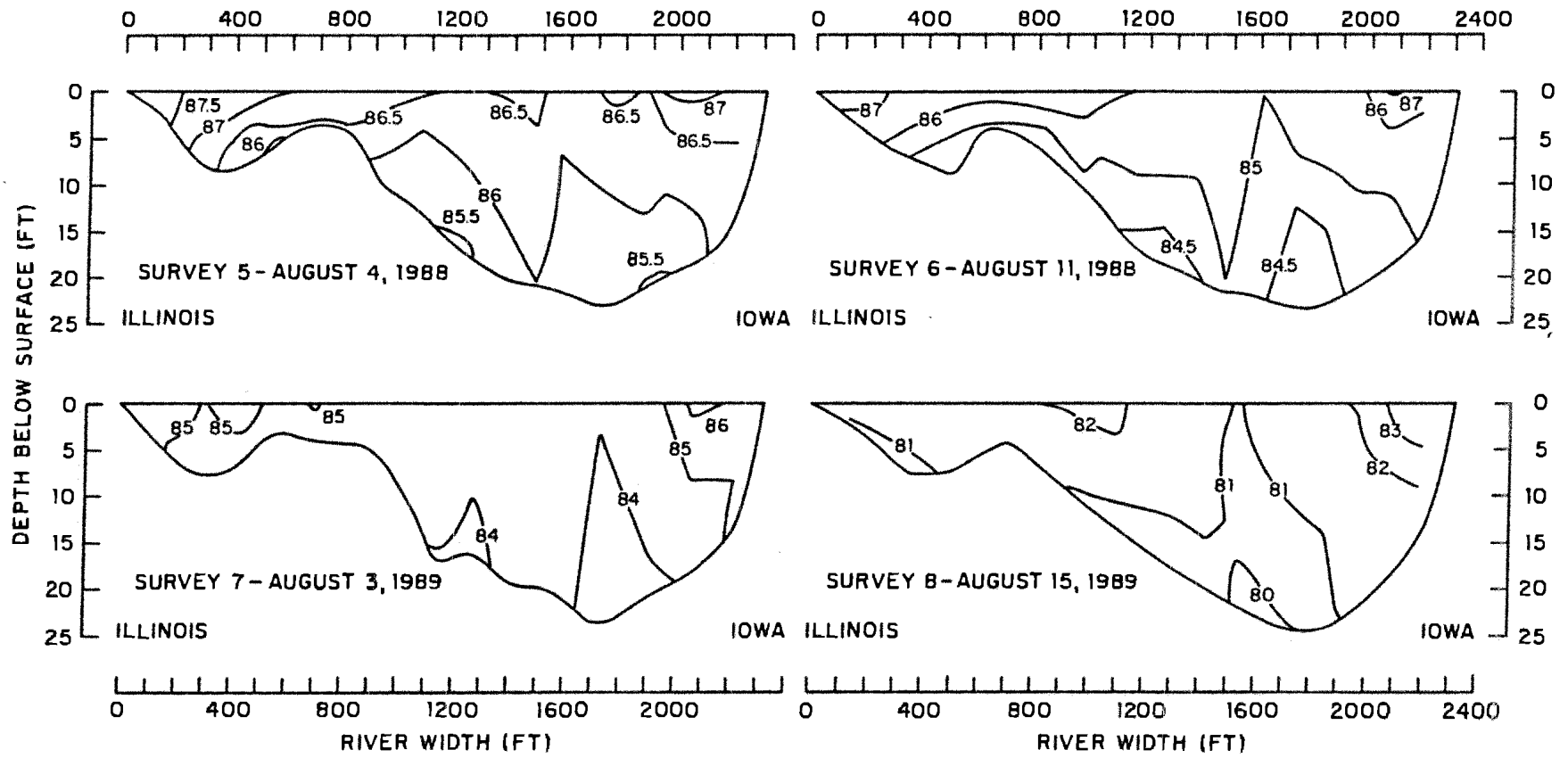

Figure 10. Continued.

spots". The temperature distributions in Group A were more nonuniform due to incomplete mixing of the effluent with the ambient flow. The temperature distributions in Group B were fairly uniform, particularly along depth, indicating complete mixing of the effluent and the ambient flow; the degree of mixing increased with decreasing discharge ratio, as one would expect. The high-temperature spots were near the Illinois and Iowa shores, and in a part of the shallow region of the cross section downstream from the smaller discharge ports. The lower temperatures occurred in a part of the deep region of the cross section. The reason for higher temperatures near the Iowa shore and in the shallow region downstream of the smaller discharge ports is the relative deficiency of dilution water supplied by the ambient flow in these regions. The lower temperatures in the deep region are due to the relative excess of dilution water in this region. The high temperatures in the region near the Illinois shore, which was nearly stagnant, are partly due to absorption of solar radiations, and partly due to buoyant spread of warm water in Group A, and flow recirculation in Group B.

**A. Permissible Load Factor.** To evaluate the applicability of the existing temperature monitoring curve (TMC) at low river flows, the maximum excess temperature in the "hot spots" at the downstream section was determined for each survey. The maximum excess temperatures,  $(T - T_a)_{\max 1 \text{ obs}}$ , in the downstream section and their distances from the Illinois shore are given in table 2. The maximum excess temperatures occurred near the Iowa shore, at about 2100 ft from the Illinois shore, with the following exceptions: (1) in survey 1, the location of  $(T - T_a)_{\max 1 \text{ obs}}$  was at about 1450 ft from the Illinois shore; (2) in survey 2, the same  $(T - T_a)_{\max 1 \text{ obs}}$  also occurred at about 1350 ft from the Illinois shore; and (3) the maximum excess temperature near the Illinois shore in survey 5 was not considered in the present analysis, because the warmer temperatures in this region are partly due to absorption of solar radiations. The reason  $(T - T_a)_{\max 1 \text{ obs}}$  in survey 1 did not occur near the Iowa shore is the relatively higher river flows along the Iowa bank from the Wapsipinicon River at the time of the survey (see figure 8).

The maximum excess temperatures at full load,  $(T - T_a)_{\max 1 \text{ est}}$ , were estimated from  $(T - T_a)_{\max 1 \text{ obs}}$  under the assumption that the local excess temperatures are directly proportional to the plant load. The resulting  $(T - T_a)_{\max 1 \text{ est}}$  are listed in table 2.  $(T - T_a)_{\max 1 \text{ est}}$  for each 500-ft downstream section, along with the existing TMC and the perfect mixing curve, are plotted in figure 11. The following observations were made from figure 11:

Table 2. Maximum Local Excess Temperature

Survey No.	Distance from Illinois Shore ft	Maximum Local Excess Temperature (T-T <sub>a</sub> ) <sub>max 1 obs</sub> °F	Plant Load $P = \frac{Q_d \Delta T_e}{Q_{df} \Delta T_{ef}}$ %	$\frac{(T-T_a)_{\text{max 1 est}}}{P/100}$ °F
1	1450	2.8	0.37	7.6
2	2000 & 1350	4.5	0.97	4.6
3	2100	4.8	0.79	6.1
4	2150	3.3	0.37	8.9
5	2050	0.9	0.11	8.2
6	2050	2.7	0.43	6.3
7	2050	3.9	0.93	4.2
8	2150	5.8	0.87	6.7

$Q_d$  = Actual effluent discharge;  $Q_{df}$  = Maximum effluent discharge = 2094 cfs

$\Delta T_e$  = Actual effluent excess temperature;  $\Delta T_{ef}$  = Effluent excess temperature at full load = 23°F.

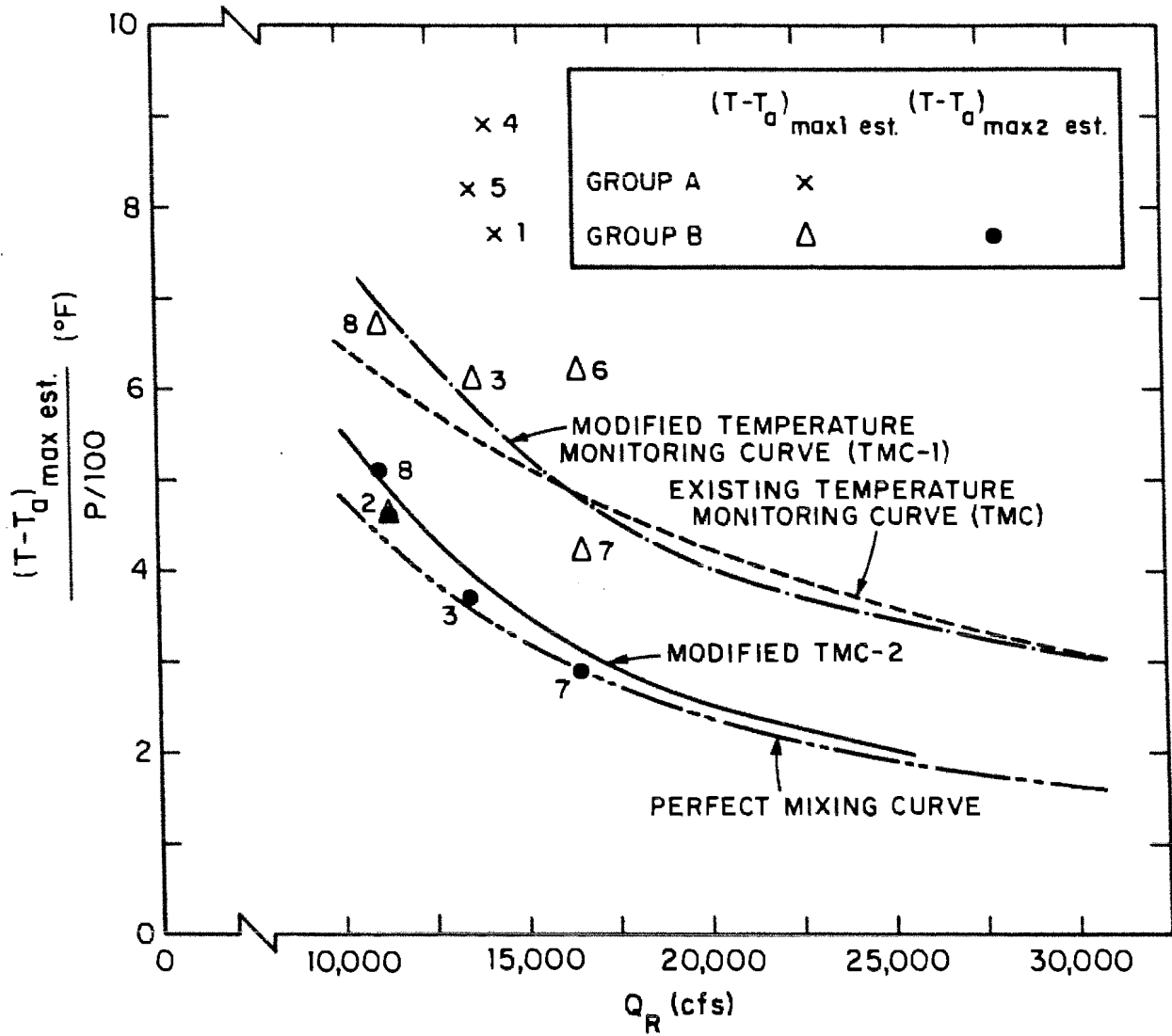

Figure 11. Modified temperature monitoring curves.

1. The performance of the diffuser was better for Group B flows than Group A flows, because of the lower discharge ratios for the former. For a given river discharge, the discharge ratio decreases with increasing condenser water discharge. The diffuser should, therefore, be operated at the maximum condenser water discharge to minimize the excess temperatures in the "hot spots".
2. The condenser water discharge in surveys 2,3,7, and 8 was full capacity of the circulating water pumps, 2,094 cfs. The results of these surveys were used to check the applicability of the existing TMC. Though the flow conditions in surveys 2 and 8 are almost same,  $(T - T_a)_{\max 1 \text{ est}}$  is significantly lower in the former than the latter. The lower value of  $(T - T_a)_{\max 1 \text{ est}}$  in survey 2 is likely due to relatively high flows from the Wapsipinicon River (see figure 8). The station should be in compliance with the thermal standards irrespective of the flows from the Wapsipinicon River; the value of  $(T - T_a)_{\max 1 \text{ est}}$  for survey 2 were, therefore, not used to verify the existing TMC.  $(T - T_a)_{\max 1 \text{ est}}$  for surveys 3 and 8 are above, and for survey 7 below, the existing TMC.; hence the existing TMC needs adjustment. The modified temperature monitoring curve, TMC-1, is also presented in figure 11, and should be used for estimating the plant load at low river flows so that plant operation with the present diffuser-system configuration will be in compliance with the thermal standards.

**B. Method for Monitoring Plume.** The field data for low river flows showed that the maximum excess temperature in the 500-ft downstream section occurred near the water surface at about 2,100 ft from the Illinois shore. Based on this observation, the following procedure, which is simpler than the existing procedure, for monitoring the thermal plume is recommended:

- (i) Measure the ambient water temperature,  $T_a$ , in the middle of the section 1000-ft upstream at about 2 ft below the water surface.
- (ii) Use TMC-1 in figure 11 to determine the plant load factor.
- (iii) Operate the plant with all circulating pumps at full capacity.
- (iv) Measure temperatures in the 500-ft downstream section from about 1900 ft to 2200 ft from the Illinois shore, at about 50-foot intervals and at a depth of about 2 ft below the water surface, and identify the



maximum temperature,  $T_{\max}$ . Compute the maximum exceeds temperature,  $\Delta T_{\max} = T_{\max} - T_a$ . Both  $T_{\max}$  and  $\Delta T_{\max}$  should be below the corresponding prescribed permissible maxima.

#### V. OPTIMUM DIFFUSER CONFIGURATION.

Optimization of the diffuser configuration involves two steps: (i) determination of the condenser-water discharge distribution along the diffuser to achieve uniform mixing of the effluent (to eliminate local "hot and cold spots"); and (ii) determination of the optimum value of  $R_0$ . To achieve the former, the regions of excess temperature in the 500-ft downstream section that are higher than the fully mixed excess temperature,  $\Delta T_{\text{mix}} = (T_{\text{mix}} - T_a)$ , were delineated for surveys 2,3, 7, and 8, and are shown in figure 12. There are only two or three such regions in each of these surveys; one, near the Iowa shore; and the others, on the left-hand side of the deeper portion of the river. The excess temperatures in the latter regions of each of these surveys are only slightly higher than  $\Delta T_{\text{mix}}$ . Because perfect mixing can be achieved only in theory, the temperature distribution and consequently the diffuser-discharge distribution in this region needs no modification. The excess temperatures in the former region are significantly higher than  $\Delta T_{\text{mix}}$ . To lower the excess temperatures in this region close to  $\Delta T_{\text{mix}}$ , a portion of the diffuser flow from this region should be discharged in a region where the excess temperatures are below  $\Delta T_{\text{mix}}$ ; such a region exists in the deeper portion of the river section, as shown in figure 12. The amount of diffuser flow to be redistributed was estimated by comparing the transverse distributions of heat flux in the 500-ft downstream section for the existing conditions to that for fully mixed conditions; the normalized distributions for the two conditions are shown in figure 13. It is assumed that the discharge distributions in the 500-ft downstream section for the two conditions are the same. The heat fluxes in the middle of the section and near the Iowa shore for the existing conditions are, respectively, lower and higher than those for the fully mixed conditions, as one would expect. The difference in heat fluxes near the Iowa shore (beyond approximately  $z = 1900$  ft from the Illinois shore) for the two conditions ranges from about 0.4 to 5.0 percent of the total heat flux of the plant. Due to inherent uncertainties in field measurements, a reduction in the condenser-water discharge in this region equal to the maximum of the above range, i.e. 5.0 percent of the total condenser water discharge,  $Q_d$ , is suggested. The condenser-water discharge beyond  $z = 1900$  ft is about 11.5 percent of  $Q_d$ ; hence the condenser water discharge in this region needs to be reduced by 43 percent of the existing discharge. The condenser water discharge in the deeper portion of the section will be increased by the corresponding

24

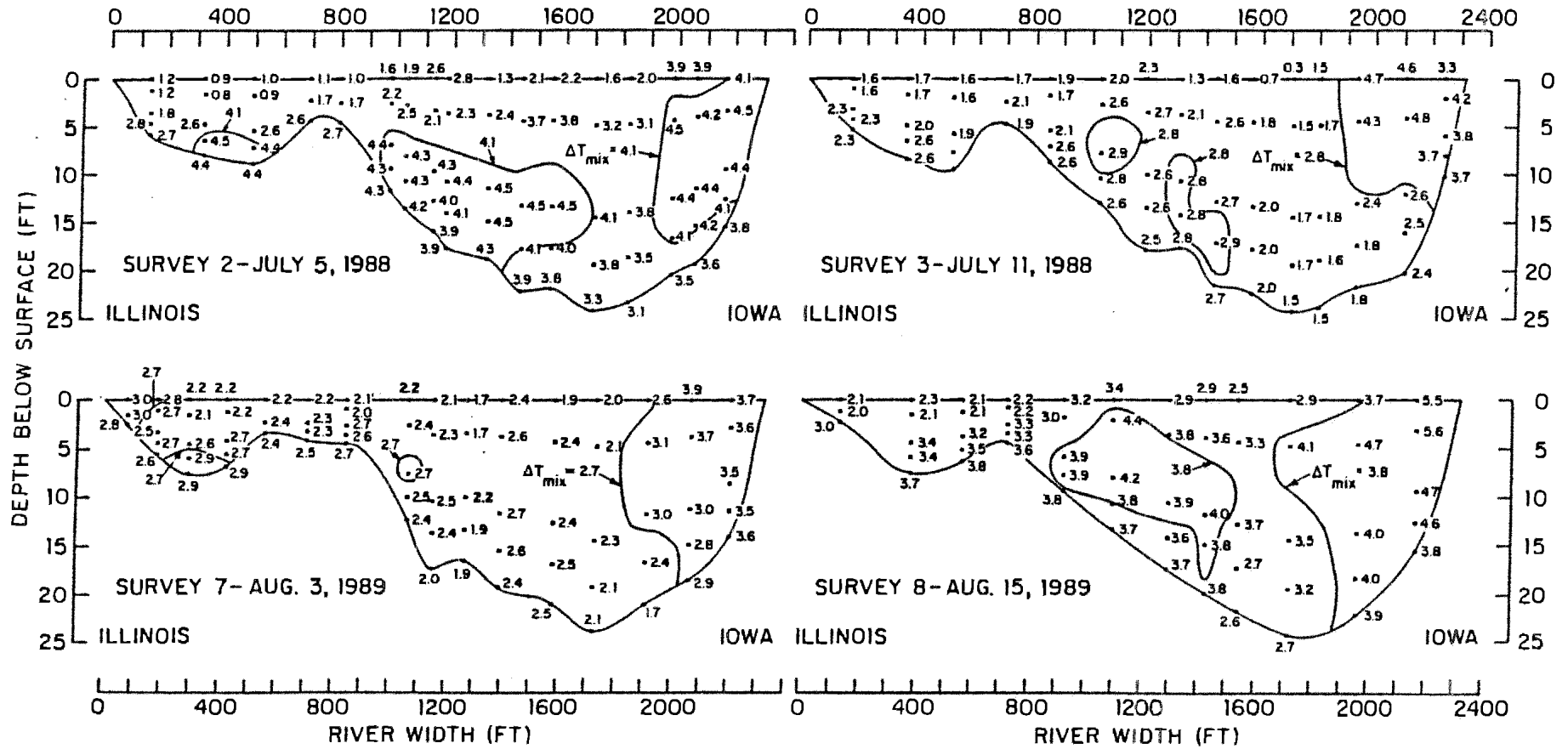
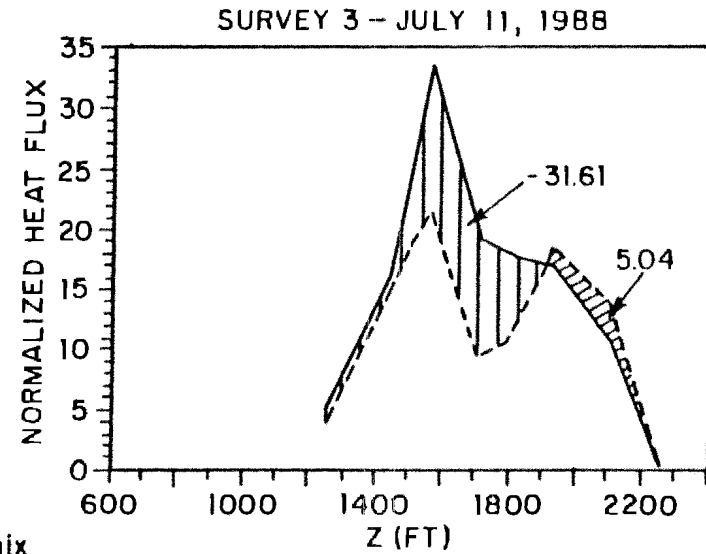
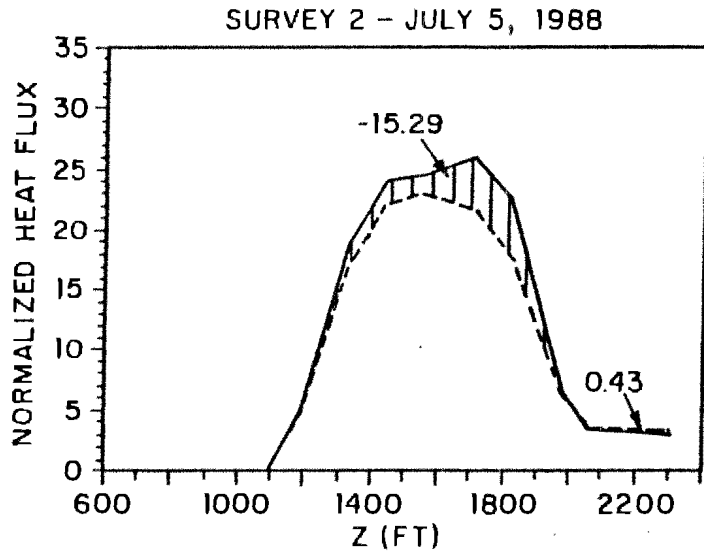

Figure 12. Temperature-rise distributions in the downstream section.



$$\frac{\Delta Q_R \Delta T_{mix}}{Q_d \Delta T_e}$$

$$\frac{\Delta Q_R \Delta T}{Q_d \Delta T_e}$$

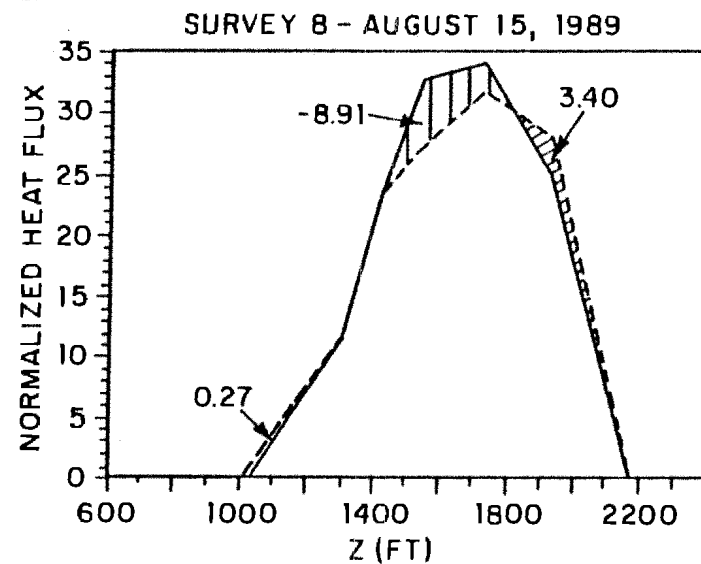
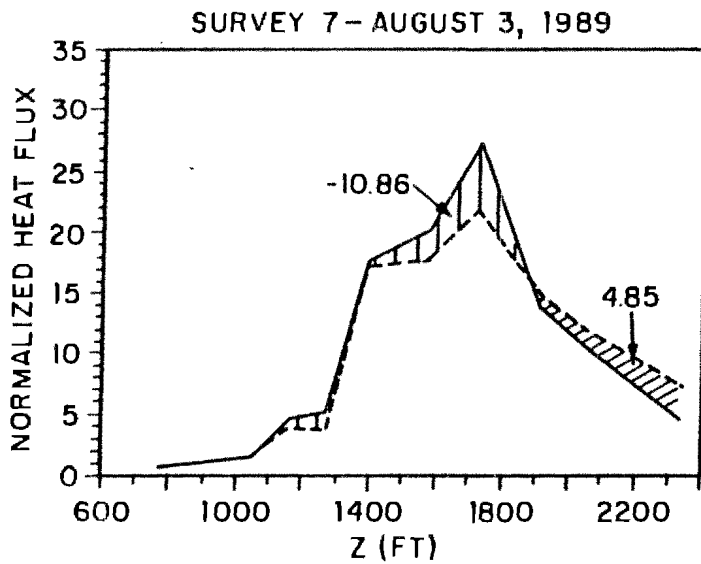

Figure 13. Normalized transverse distributions of heat flux in the downstream section.

mount. However, the distribution of the modified condenser water discharge can be determined only by means of a physical model study of the diffuser system.

If the distribution of the condenser water discharge could be modified to eliminate the "hot spot" with the maximum excess temperature, as described above, TMC should be based on the estimated second highest excess temperatures at the full load,  $(T - T_a)_{\max 2 \text{ est}}$ , which for surveys 2,3,7 and 8 are given in table 3, and also are plotted in figure 11. Although the data for surveys 3 and 7 show perfect mixing, the second modified temperature monitoring curve, TMC-2, is drawn a little above the perfect mixing curve because perfect mixing is unlikely to be achieved in practice. According to TMC-2, thermal standard A can be satisfied for river discharges as low as about 11,000 cfs.

The second step in optimizing the diffuser configuration was determination of the optimum value of  $R_0$ . The critical discharge ratio for the present diffuser-pipe system is estimated to be about 9.3. An idealized diffuser with  $R_0 = 9.3$  should produce complete mixing of 2094 cfs of the effluent with ambient flows smaller than about 21,570 cfs which is significantly larger than the minimum river discharge of 16,000 cfs currently required to satisfy the thermal standards at the full plant load. Therefore, there is no need to increase the value of  $R_0$  for the diffuser-pipe system.

## VI. SUMMARY AND CONCLUSIONS

A one-dimensional analytical model, and field data for eight surveys collected during the summers of 1988 and 1989 when the river discharges were unusually low were used to evaluate the performance of, and to optimize, the present QCNGS diffuser-pipe system. The results of the analytical model were in agreement with the field data. The performance of a diffuser system depends primarily on discharge ratio  $R$ . There exists a discharge ratio, termed critical discharge ratio  $R_0$ , at which the entire ambient flow is mixed with the effluent. Smaller  $R$  signifies more complete mixing of the effluent with the ambient flow. The value of  $R_0$  for the existing diffuser system is about 9.3. The discharge ratio in the field surveys ranged from 4.4 to 12.8. The overall mixing of the effluent with the ambient flow in surveys with  $R < R_0$  was almost uniform, except for local "hot spots" and "cold spots" which occurred, respectively, due to relative deficiency and excess of dilution water. The existing temperature-monitoring curve (TMC) underestimates the maximum excess temperature in the 500-ft downstream section at low river flows. A modified temperature-monitoring curve, TMC-1, based on the field data and a simple procedure for monitoring the thermal plume was developed.

Table 3. Second Highest Local Excess Temperature

Survey No.	Distance from Illinois Shore ft	Second Highest Local Excess Temperature (T-T <sub>a</sub> ) max 2 obs °F	Plant Load $P = \frac{Q_d \Delta T_e}{Q_d f \Delta T_{ef}}$ %	$\frac{(T-T_a)_{\max 2 \text{ est}}}{P/100}$
2	1300	4.5	0.97	4.6
3	1050	2.9	0.79	3.7
7	1050	2.7	0.93	2.9
8	1100	4.4	0.87	5.1

The performance of the diffuser system could be improved by reducing the condenser water discharge near the Iowa shore and increasing it in the deeper portion of the river section. A physical model study of the diffuser system is recommended to determine the optimum distribution of the condenser-water discharge. Another modified temperature-monitoring curve, TMC-2, based on the modified distribution of the condenser-water discharge was developed. For TMC-2, the minimum river discharge required to comply the thermal limitation at the full plant load is about 11,000 cfs.

### **REFERENCES**

Commonwealth Edison (1981), "Supplement to 316 (a) and 316(b) Demonstration for the Quad Cities Nuclear Generating Station."

Jain, S.C., Sayre, W.W., Akyeampong, Y.A., McDougall, D., and Kennedy, J.F. (1971), "Model Studies and Design of Thermal Outfall Structures Quad-Cities Nuclear Plant," IIHR Report No. 135, Iowa Institute of Hydraulic Research, The University of Iowa, Iowa City, Iowa.

## PART TWO

### ANALYSIS OF COOLING POTENTIAL OF THE COOLING CANAL

#### I. INTRODUCTION

A short time after QNCGS went on-line using the diffuser-pipe system to discharge its condenser water into the Mississippi River, the station was required to operate on a completely closed-cycle cooling system; consequently a spray-canal system was constructed to cool the condenser water. The spray-canal system was used as the sole cooling system for the station, until the station was permitted to go back to the open-cycle cooling system. The spray modules and the lift pumps to draw the condenser water from the discharge flume to the spray canal since have been removed. However, the existing canal could be used as a cooling pond in conjunction with the diffuser-pipe system if it is found to be effective in cooling the condenser water during periods when the river flow conditions do not permit the plant to operate at full load using only the once-through diffuser-pipe cooling system.

A plan view of the cooling canal is shown in figure 14. The canal is about 15,000 ft in length; and at normal water level, 200 ft in width at the free surface and 10 ft in depth. The canal begins near the discharge flume of the plant, goes around the plant, and terminates in the intake flume of the plant. The cooling potential of the cooling canal is analyzed in this Part of the report.

#### II. ANALYTICAL MODEL

A one-dimensional analytical plug-flow model was used to evaluate the cooling potential of the cooling canal. The model is shown schematically in figure 15. The heated condenser water is discharged at temperature  $T_i$  into one end of the canal, from where it proceeds through the canal losing heat to the atmosphere, and exists at the other end of the canal at temperature  $T_o$ . The surface heat exchange rate per unit water-surface,  $\phi$ , area can be expressed by the equilibrium model of Edinger and Geyer (1965) as

$$\phi = -K (T - T_e) \quad (10)$$

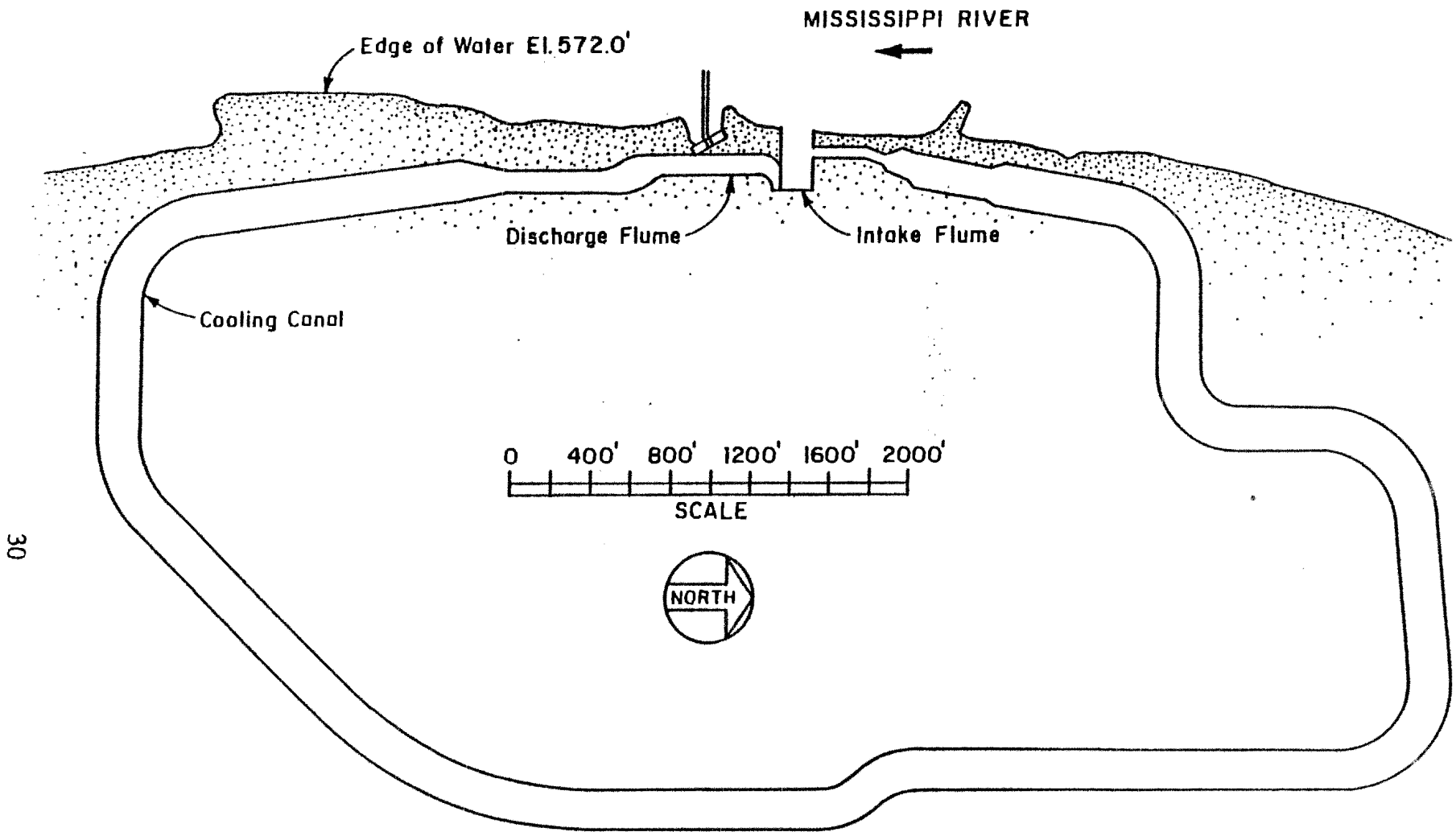

Figure 14. Plan view of the QCNGS cooling canal.



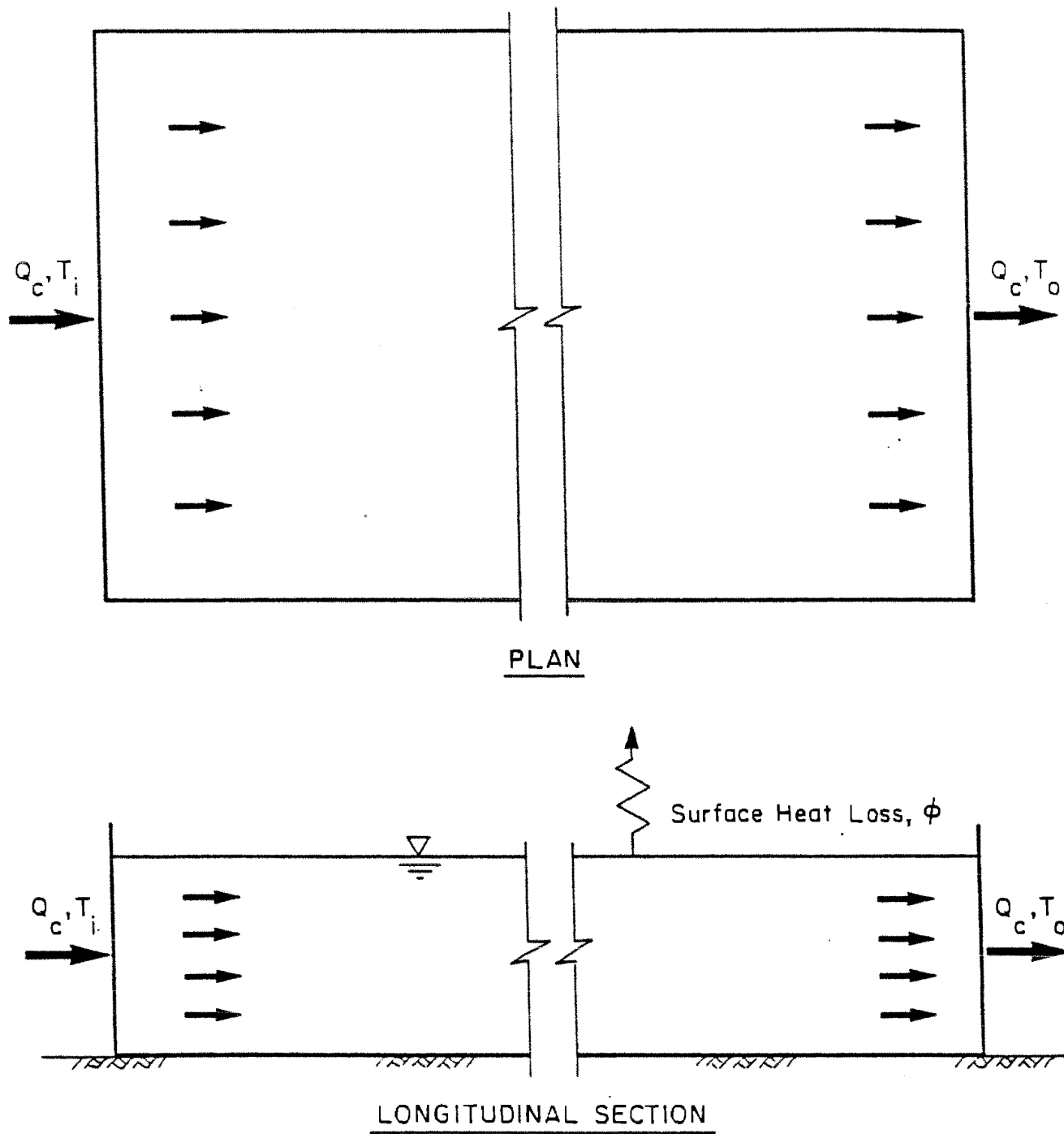

Figure 15. Schematic for one-dimensional plug-flow analysis of a cooling canal

where  $K$  = surface heat-exchange coefficient;  $T$  = local water-surface temperature; and  $T_e$  = equilibrium water temperature (i.e. the water temperature at which there is no heat exchange with the atmosphere). For a steady flow conditions, the difference,  $H$ , between the heat influx to the canal,  $\rho C_p Q_c T_i$ , and heat efflux from the canal,  $\rho C_p Q_c T_o$ , is equal to the rate of heat transfer from the water surface to the atmosphere; i.e.,

$$H = \rho C_p Q_c (T_i - T_o) = \int_0^A K(T - T_e) dA \quad (11)$$

in which  $A$  = water-surface area of the canal;  $C_p$  = specific heat of water; and  $Q_c$  = condenser-water discharge through the canal. Equation 11 can be written

$$\rho C_p Q_c (dT/dA) = K(T - T_e) \quad (12)$$

The solution of Eq. 12 is

$$(T_o - T_e)/(T_i - T_e) = \exp(-r) \quad (13)$$

where

$$r = KA/(\rho C_p Q_c) \quad (14)$$

For given  $T_o$ ,  $T_i$ ,  $T_e$ ,  $K$ , and  $A$ ,  $Q_c$  can be obtained from Eq. 13.

### III. COOLING POTENTIAL OF COOLING CANAL

The flow rate,  $Q_c$ , of the condenser-water that can be discharged into the cooling canal was obtained from Eq. 13 for the condition that the difference between influx and efflux temperatures is equal to that maximum condenser-water temperature rise; i.e.  $T_i - T_o = 23^\circ \text{F}$ ; the results are presented in figure 16. The discharge  $Q_c$  was computed for  $(T_o - T_e)$  ranging from  $1^\circ \text{F}$  to  $5^\circ \text{F}$ , and for  $K = 110$  and  $147 \text{ Btu}/(\text{°F} \cdot \text{ft}^2 \cdot \text{day})$ , which are the minimum and the maximum values of  $K$  during summer (Thackston) 1974). Ideally,  $T_o$  should be equal to the ambient river temperature which is generally higher than the equilibrium water temperature due to external thermal loads imposed on the river.  $Q_c$  ranges from about 18 to 34 cfs (0.9 to 1.6 percent of the maximum condenser-water

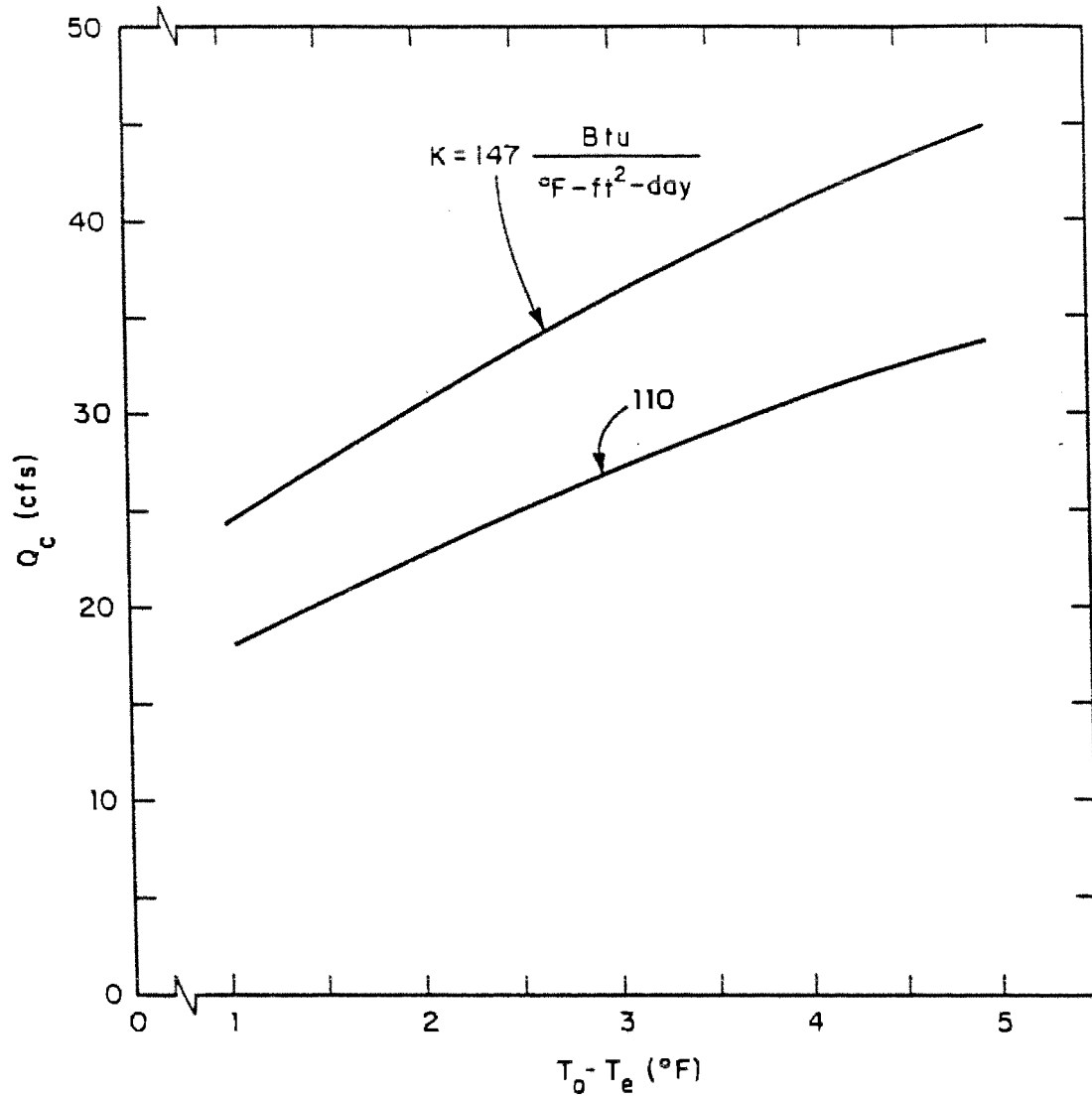

Figure 16. Cooling-canal discharge.

discharge) for  $K = 110 \text{ Btu}/(^{\circ}\text{F} - \text{ft}^2\text{-day})$  and from 24 to 45 cfs (1.1 to 2.2 percent of the maximum condenser-water discharge) for  $K = 147 \text{ Btu}/(^{\circ}\text{F} - \text{ft}^2\text{-day})$ .

The cooling canal could be beneficially used when the river flow is below 16,000 cfs for the present diffuser, and 11,000 cfs for the optimum diffuser described in Part One of this report. The flow-duration curve for the Mississippi River at Clinton, Iowa, based on the discharge data for the period 1 Oct. 1937 - 30 Sept. 1987 is shown in figure 17. (The discharge data prior to 1937, when the locks and dams in the Mississippi River were put into operation, was not used in developing the flow duration curve). The percent of time in any year the discharge is less than 16000 cfs and 11,000 cfs is 2.98 percent and 0.16 percent, respectively.

On the assumption that heat flux through the condensers is proportional to the electric power generated by the plant and the maximum heat flux at the rated power output of 1,600 MW at QCNGS corresponds to the condenser-water discharge of 2094 cfs at  $23^{\circ} \text{ F}$  above ambient water temperature, the additional electric energy per year,  $E$ , that could be generated by using the cooling canal is

$$E = 1600 \times \frac{Q_c}{2094} \times N \quad (\text{MW-day}) \quad (15)$$

in which  $N$  is the number of days in a year the river flow is less than a given value. The values of  $E$  for river flows less than 16,000 cfs and 11,000 cfs are given in figure 18. The additional energy per year that could be generated by using the existing diffuser configuration in conjunction with the cooling canal ranges from about 200 to 370 MW-day for  $K = 147 \text{ Btu}/(^{\circ}\text{F} - \text{ft}^2 - \text{day})$  and about 150 to 280 MW-day for  $K = 110 \text{ Btu}/(^{\circ}\text{F} - \text{ft}^2 - \text{day})$ . The value of  $E$  for the optimum diffuser configurations is significantly less; it ranges from about 10 to 19 MW-day for  $K = 147 \text{ Btu}/(^{\circ}\text{F} - \text{ft}^2 - \text{day})$  and from about 8 to 14 MW-day for  $K = 110 \text{ Btu}/(^{\circ}\text{F} - \text{ft}^2 - \text{day})$ . It should be mentioned that a part of the additional electrical energy would be used to pump water into the cooling canal.

#### IV. CONCLUSIONS

The cooling canal could be used to cool only about 0.9 to 2.2 percent of the maximum condenser-water discharge. About 8 - 19 MW-day of additional electric energy per year could be generated if the cooling canal in conjunction with the optimum diffuser configurations is used.

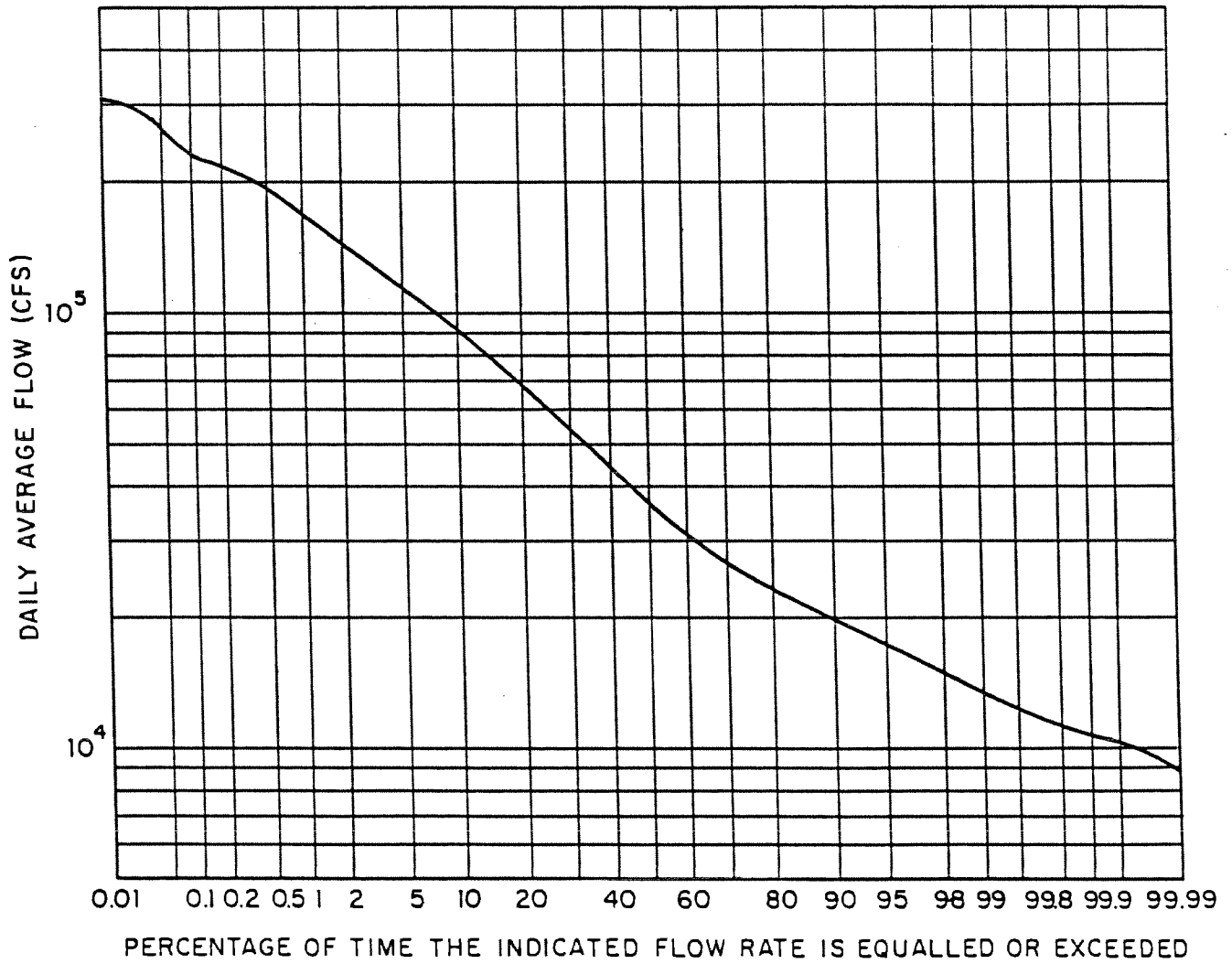

Figure 17. Flow-duration curve for the Mississippi River at Clinton, Iowa (10 Oct. 1937 to 30 Sept. 1987)

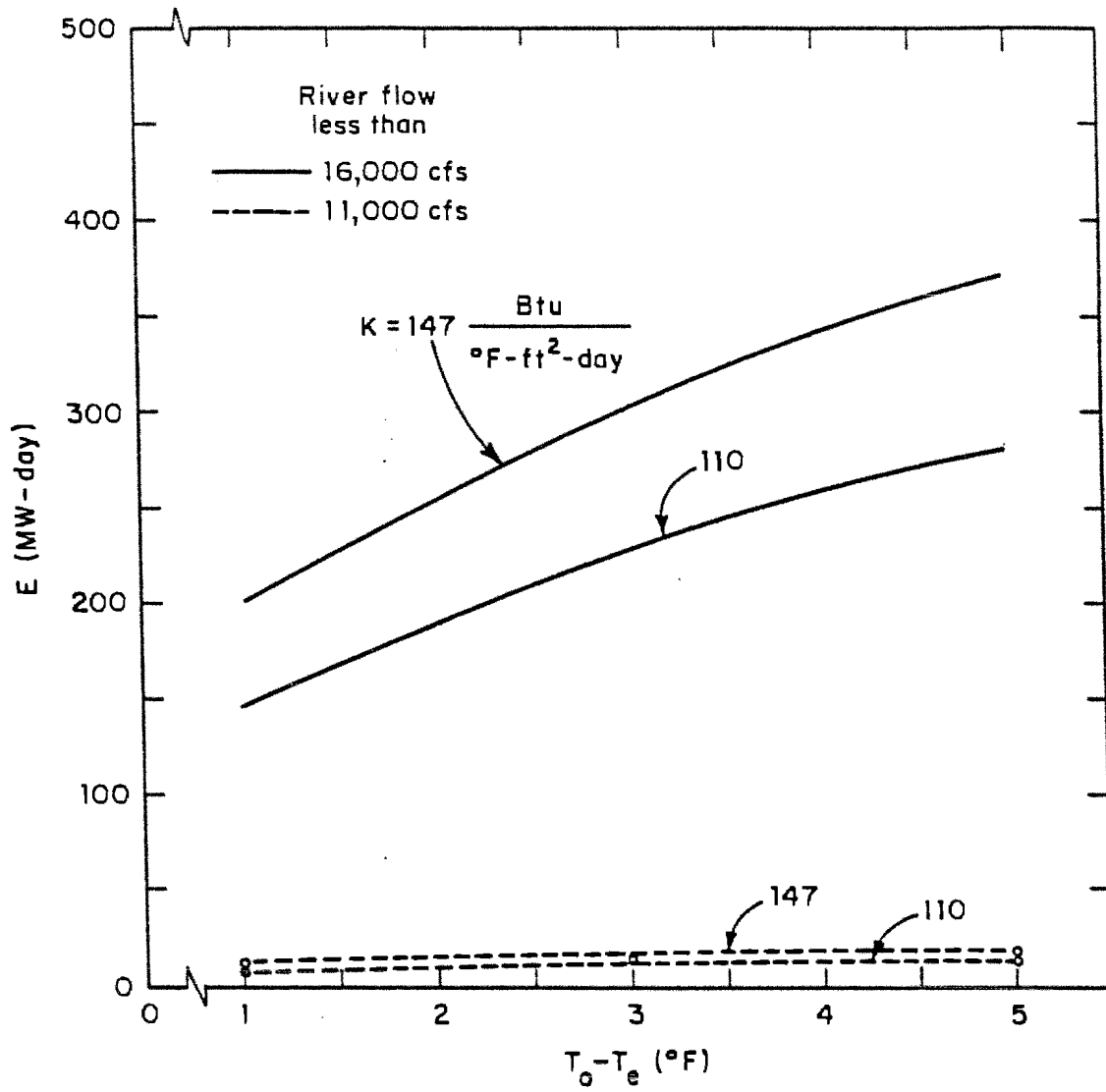

Figure 18. Additional electric energy per year generated by using the cooling canal.

**REFERENCES**

Edinger, J.E., and Geyer, J.C., "Heat exchange in the environment," Publication No. 65-902, Edison Electric Institute, New York, New York, 1965.

Thackston, E.L., "Effect of geographical variation on performance of recirculating cooling ponds," EPA - 660/2 - 74 - 085, U.S. Environmental Protection Agency, Corvallis, Oregon, December 1974.

### **PART THREE**

## **TREND ANALYSIS OF THE MISSISSIPPI RIVER FLOW REGIME**

### **I. INTRODUCTION**

The drought of 1988 and 1989 caused an increased awareness among the electric power utilities, including CECO, of potential effects of regional climate. It is of interest for future use in managing waste heat from QCNGS to find out if there are identifiable trends in daily discharge and temperature data of the Mississippi River.

The discharge and temperature data for the Mississippi River at Clinton, Iowa, were analyzed to identify trends in the time series of water discharge and temperature of the river. The procedure used is the nonparametric trend test described by Hirsh and Slack (1984) and discussed by Hirsh (1988), Lettenmaier (1988), El-Shaaravi and Damsleth (1988) and Barryman et al (1988). The test is appropriate for seasonal and serially-correlated data.

### **II. PRELIMINARY DATA ANALYSIS**

The trend analysis described in this Part of the report is based on daily discharge and daily maximum water temperature records for the periods 1875-1984, collected by USGS at Clinton, Iowa. The daily discharge data were averaged to monthly values, which constitute the basis for our analysis. The monthly discharge data are presented in figure 19, and the temperature data are shown in figure 20. Visual inspection of the data record reveals no apparent long-term trend; however, it does show decreasing flows in the past 3 years. The trend analysis was performed with this recent period in mind. An extension of the seasonal Kendall test (Hirsh et al. 1982) was used as the analysis tool. This extension, proposed by Hirsh and Slack (1984), allows for significant serial correlation between variables corresponding to successive seasons (or months) within a year, but requires negligible correlation between variables corresponding to the same season (or month) in successive years. This assumption was satisfied for the present discharge and temperature data. Autocorrelations for one-month and two-month lag in the discharge data for the same month and for one-month lag in the temperature data for the same month are given in table 4. For temperature, only one-month lag (Lag-1) values are given because the small sample size combined with missing data do not justify meaningful estimates for higher lag values. The autocorrelation-function of the monthly discharges shown in figure 21 displays, as ex



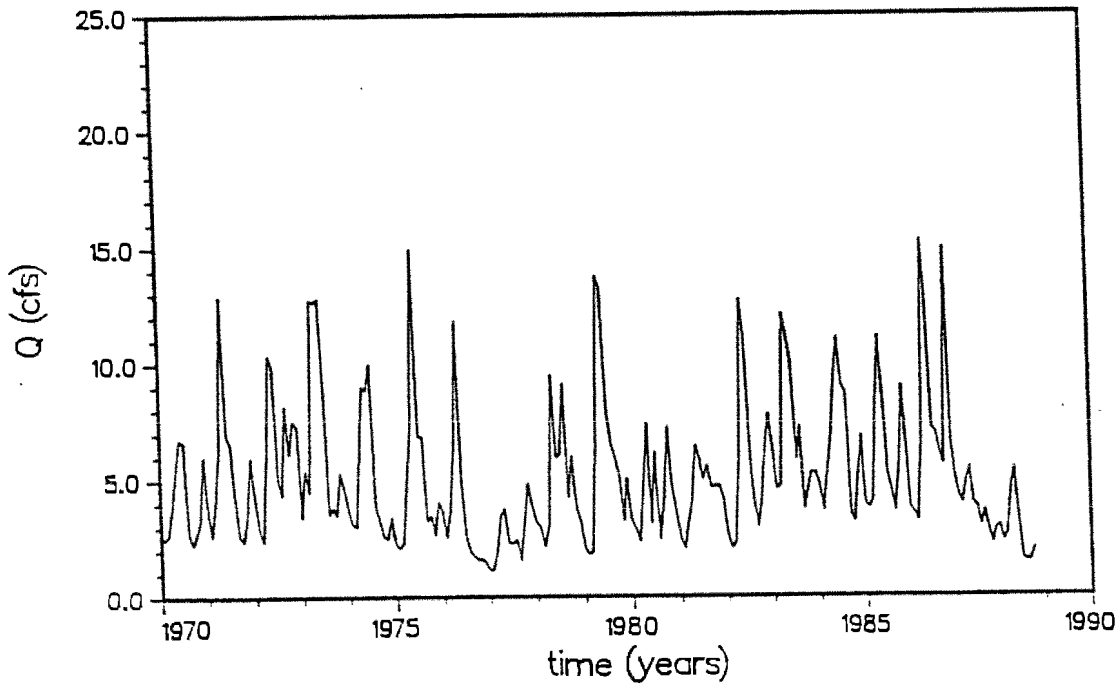
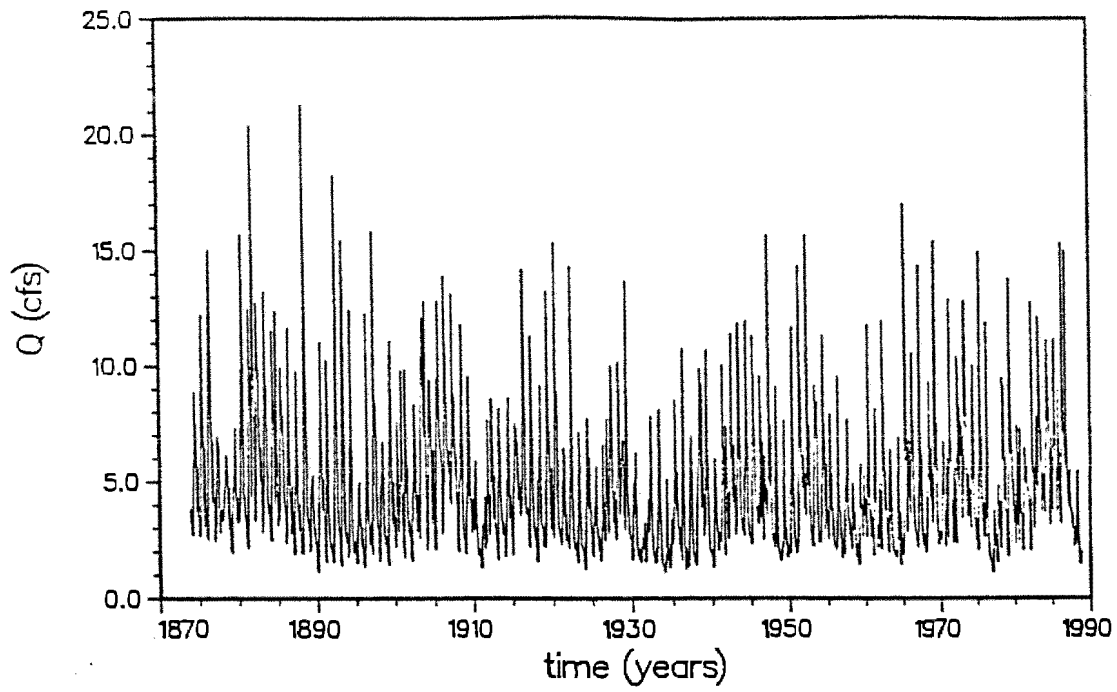

Figure 19. Monthly discharge of the Mississippi River at Clinton, Iowa.

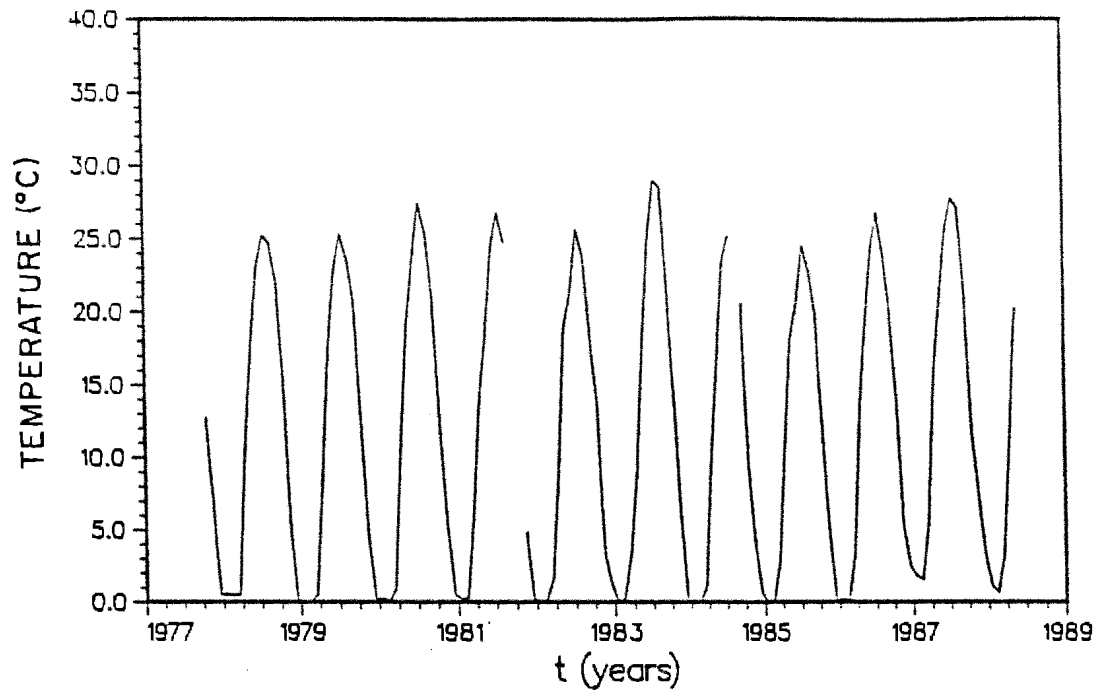

Figure 20. Monthly water temperatures of the Mississippi River at Clinton, Iowa.

Table 4. Auto correlations of discharges and temperatures for the same month.

Month	Discharge		Temperature
	Lag 1	Lag 2	Lag 1
January	0.20	0.18	0.04
February	0.30	0.15	-0.04
March	0.22	0.18	-0.03
April	-0.03	-0.02	0.25
May	0.17	0.01	0.23
June	0.27	0.26	-0.24
July	0.31	0.16	-0.16
August	0.17	0.10	-0.28
September	0.16	0.08	0.11
October	0.15	0.05	-0.18
November	0.22	0.20	-0.08
December	0.07	0.15	0.31

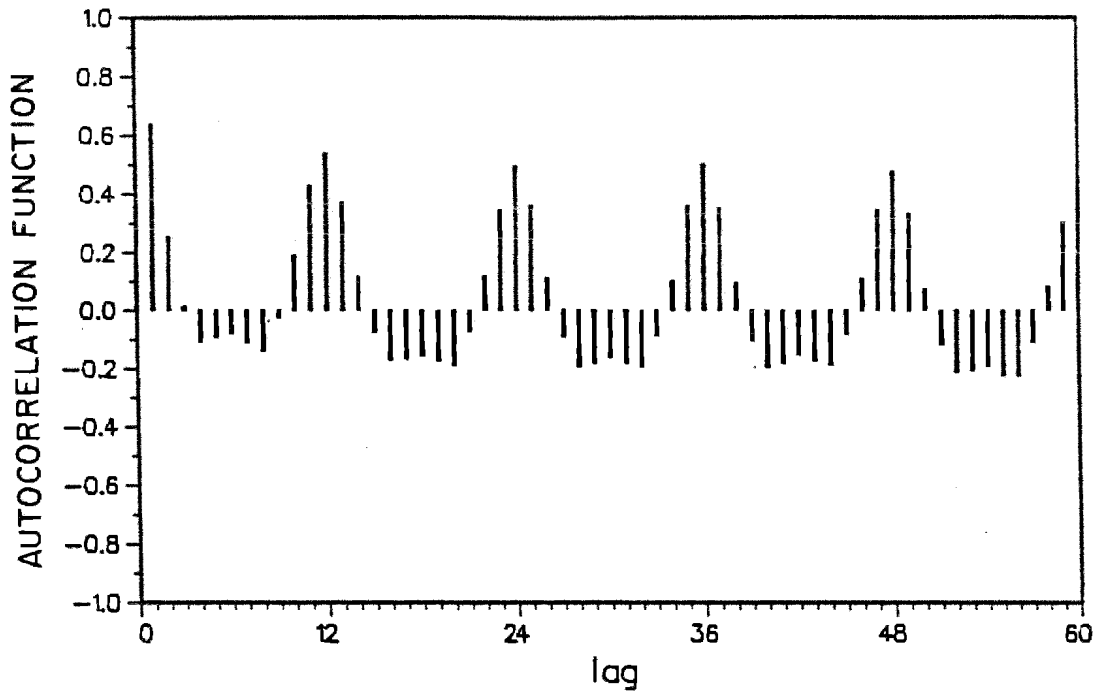

Figure 21. Autocorrelation function of the monthly discharge data of the Mississippi River at Clinton, Iowa.

pected, a strong periodic behavior; however the correlations of discharges for same months given in table 4 are low. Similarly, the correlation in monthly temperature is about 0.6 for the one-month lag and 0.35 for the two-month lag. But the correlations of temperatures for the same month given in table 4 are small.

Since there were no missing data in the discharge case and due to the continuous nature of the discharge data, the full form of the test could be used. In case of water temperature data there were quite a few missing values. Since the test was applied to monthly averages the missing data do not present a serious problem as long as their number was low (less than 10). Those months with significant number of missing data (see figure 20) were declared missing and a modified version of the test was used.

### III. THE TEST

For the sake of completeness in presenting this work, a brief description of the seasonal Mann-Kendall test is given below.

For the seasonal data, with  $m$  seasons, organized in the form of a matrix

$$X = \begin{vmatrix} X_{11} & X_{12} & X_{1m} \\ X_{21} & X_{22} & X_{2m} \\ X_{n1} & X_{n2} & X_{nm} \end{vmatrix} \quad (16)$$

another matrix of ranks can be constructed

$$R = \begin{vmatrix} R_{11} & R_{12} & R_{1m} \\ R_{21} & R_{22} & R_{2m} \\ R_{n1} & R_{n2} & R_{nm} \end{vmatrix} \quad (17)$$

with elements  $R_{ij}$  defined as

$$R_{ij} = [n+1 + \sum_{k=1}^n \text{sgn}(X_{ij} - X_{jk})]/2 \quad (18)$$

with

$$\text{sgn}(x) = \begin{cases} +1 & x > 0 \\ 0 & x = 0 \\ -1 & x < 0 \end{cases} \quad (19)$$

As a result, each column of R is a permutation of indices (1,2,...,n), and to check for linear trend correlation of these indices with indexed time can be examined. The test statistic for the jth season is according to Hirsh et al. (1982)

$$S_j = \sum_{i=1}^{n-1} \sum_{k=i+1}^n \text{sgn}(X_{jk} - X_{ji}) \quad (20)$$

The statistic of the seasonal test can be constructed as

$$S' = \sum_{j=1}^m S_j \quad (21)$$

This statistic is asymptotically normally distributed with zero mean and variance

$$\text{Var}(S') = \sum_j^m \sum_i^m \sigma_{ij} \quad (22)$$

For  $i = j$ ,  $\sigma_{ij} = \sigma^2 = \text{Var}(S_i)$ , and for  $i \neq j$   $\sigma_{ij} = \text{Cov}(S_i, S_j)$ . If there are no missing values, the terms  $\sigma_{ij}$  can be estimated from the data as:

$$\hat{\sigma}_{ij} = \frac{1}{3} [K_{ij} + 4 \sum_{k=1}^n R_{ki} R_{kj} - n(n+1)^2] \quad (23)$$

where

$$K_{ij} = \sum_{k=1}^{n-1} \sum_{\ell=k+1}^n \text{sgn}[(X_{ki} - X_{k\ell})(X_{\ell j} - X_{\ell j})] \quad (24)$$

In case of missing values

$$\hat{\sigma}_{ij} = \frac{1}{3} K_{ij} + \frac{1}{9} (n^3 - n)r_{ij} \quad (25)$$

where

$$r_{ij} = \frac{3}{n^3 - n} \sum_{k=1}^n \sum_{g=1}^n \sum_{h=1}^n \text{sgn}[(X_{gi} - X_{ki})(X_{gj} - X_{hj})] \quad (26)$$

Due to the asymptotic normal approximation to the distribution of  $S'$ , the null hypothesis should be rejected when

$$\frac{|S|}{\sqrt{\text{Var}(S')}} \geq Z_{\alpha/2} \quad (27)$$

where  $\alpha$  is significance level and  $Z_{\alpha/2}$  is the standard normal variable corresponding to the tail probability  $\alpha/2$ .

#### IV. APPLICATION OF THE TEST

Although the central question of the study was detection of any possible trend in the last few years, the test were applied to all consecutive five-year periods, and then to all consecutive three-year periods. The idea behind such a procedure was to verify the test and to examine if there are any other short periods in the record which look (to the test) in a similar way as the recent period. To the eye of a human observer, it seems that there are several short periods with a behavior similar to that of the period of interest. This especially evident in the record of discharge data. For example, in the early 1900s and 1950s there seems to be a decreasing trend reminiscent of the data behavior in the late 1980s.

The null hypothesis was tested at both  $\alpha = 0.05$  and  $\alpha = 0.01$  levels. The results of the performed analysis indicate no trends detected. Not a single 3 or 5 year period in discharge data displayed variations which would be classified by the test as a linear trend. The application of the test to the discharge data was straightforward since there was no missing data. The analysis of the temperature data deserves some more discussion. When the test was applied to the 10 year period 1978-1988 it indicated no trend for both 0.05 and 0.01 significance levels. When it was applied to 3 year periods beginning 1979, 1982 and 1985 it indicated linear trend in the first period. However, when the missing data were removed by interpolation no trend was indicated. It was judged that the interpolation of the monthly data for the missing period was quite accurate due to very regular pattern of the record (figure 20). Application of the test to such a short period (3 years) with missing data really stretches its capabilities.

## V. CONCLUSIONS

A nonparametric trend test was used to analyze trends in the discharge and temperature data for the Mississippi River at Clinton, Iowa. Neither long term, nor short term, trends were detected in the data.

## **REFERENCES**

Barryman, D., B. Bobeçe, D. Cluis, and J. Haemmerli, 1988. Nonparametric Test for Trend Detection in Water Quality Time Series, Water Resources Bulletin, 24(3): 545-556.

El-Shaarawi, A.H. and E. Damsleth, 1988. Parametric and Nonparametric Tests for Dependent Data, Water Resources Bulletin, 24(3): 513-520.

Hirsch, R.M., J.R. Slack, and R.A. Smith, 1982. Techniques of trend Analysis for Monthly Water Quality Data. Water Resources Research, 18(1): 107-121.

Hirsch, R.M. and J.R. Slack, 1984. A Nonparametric test for Seasonal Data with Serial Dependence. Water Resources Research, 20(6): 727-732.

Lettenmaier, D. P., 1988. Multivariate Nonparametric Test for Trend in Water Quality, Water Resources Bulletin, 24(3): 505-512.



## **Exhibit 30**

March 28, 2011 Letter from IDNR to Exelon

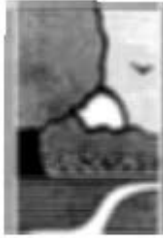

## Illinois Department of Natural Resources

One Natural Resources Way Springfield, Illinois 62702-1271  
<http://dnr.state.il.us>

Pat Quinn, Governor  
Marc Miller, Director

**March 28, 2011**

Jeremiah J. Haas  
Principal Aquatic Biologist  
Quad- Cities Nuclear Station  
22710 206<sup>th</sup> Avenue N  
Cordova, IL 61242

Re: Quad Cities Station (Station)  
Thermal & Permitting Issues

Dear Mr. Haas:

The Illinois Department of Natural Resources (IDNR) appreciates your detailed and thoughtful response of February 1, 2011, to our original letter concerning the Exelon 316 (a) report dated November 25, 2009.

We understand the 316(a) demonstration was developed using many judgments dealing with complex thermal modeling and biological issues. And since the Station has been operational for some 27 plus years in an open cycle mode, a wealth of operational data, weather and river conditions are available to draw upon. We expect the thermal model data to be quite accurate and reliable.

Mike Conlin, former IDNR employee, under contract representing Exelon, prepared a detailed time line of the fish kill. In part, this report details how fish of some 15 species died both upstream and downstream of the Station. Water temperatures above the lethal limits are suspected and winds confused the issue of where the fish actually died. Why fish did not avoid these lethal temperatures is unknown. Just prior to the fish kill the Corps of Engineers cut river flows in Pool 14 by 46% (from July 31 to August 3) during this unusually hot and dry (reduced flow naturally) period. The Station derated in response to these low flows and increased water temperatures (natural and Station induced). Yet a fish kill occurred. The kill was relatively minor in nature and undoubtedly would have been much more extensive if it were not for the quick response (Station derate) by plant staff. Once the Corps increased "normal" flows the fish kill stopped and Exelon increased power output. During 2006, Exelon at least partially caused a fish kill and to their credit in doing the right thing, they derated to minimize the kill.

Mr. Conlin's report also suggests that Exelon will retain the long term monitoring for fish and mussels, will initiate low flow-high temperature monitoring, and will coordinate with the Corps of Engineers if flows are expected to be less than 16,400 cfs. Mr. Conlin also proposes that Exelon will revise their draft 316(a) report and will address site specific zone of passage limitations. We generally agree with all these proposals but state that our objective here is to prevent any future fish kills and protect the fish and wildlife resources of the State.

If kills do occur, the DNR will evaluate them fully as Trustee of the State's Fish and Wildlife Resources, in consultation with IEPA and in accordance with the standard protocol for fish kill investigations.

We look forward to reviewing the redraft of the 316(a) report and stand ready to work with Exelon to protect and enhance the resources of the Mississippi River.

Sincerely,

A handwritten signature in black ink, appearing to read "John D. Rogner". The signature is fluid and cursive, with the first name "John" being the most prominent.

John D. Rogner  
Assistant Director

cc: Dr. James Herkert, Director, Office of Resource Conservation  
M. S. Pallo, Fisheries  
Bob Mosher, IEPA

## **Exhibit 31**

Figure 1 to Upper Mississippi River National Wildlife and Fish  
Refuge Comprehensive Conservation Plan

**Figure 1: Location of Upper Mississippi River NWR**

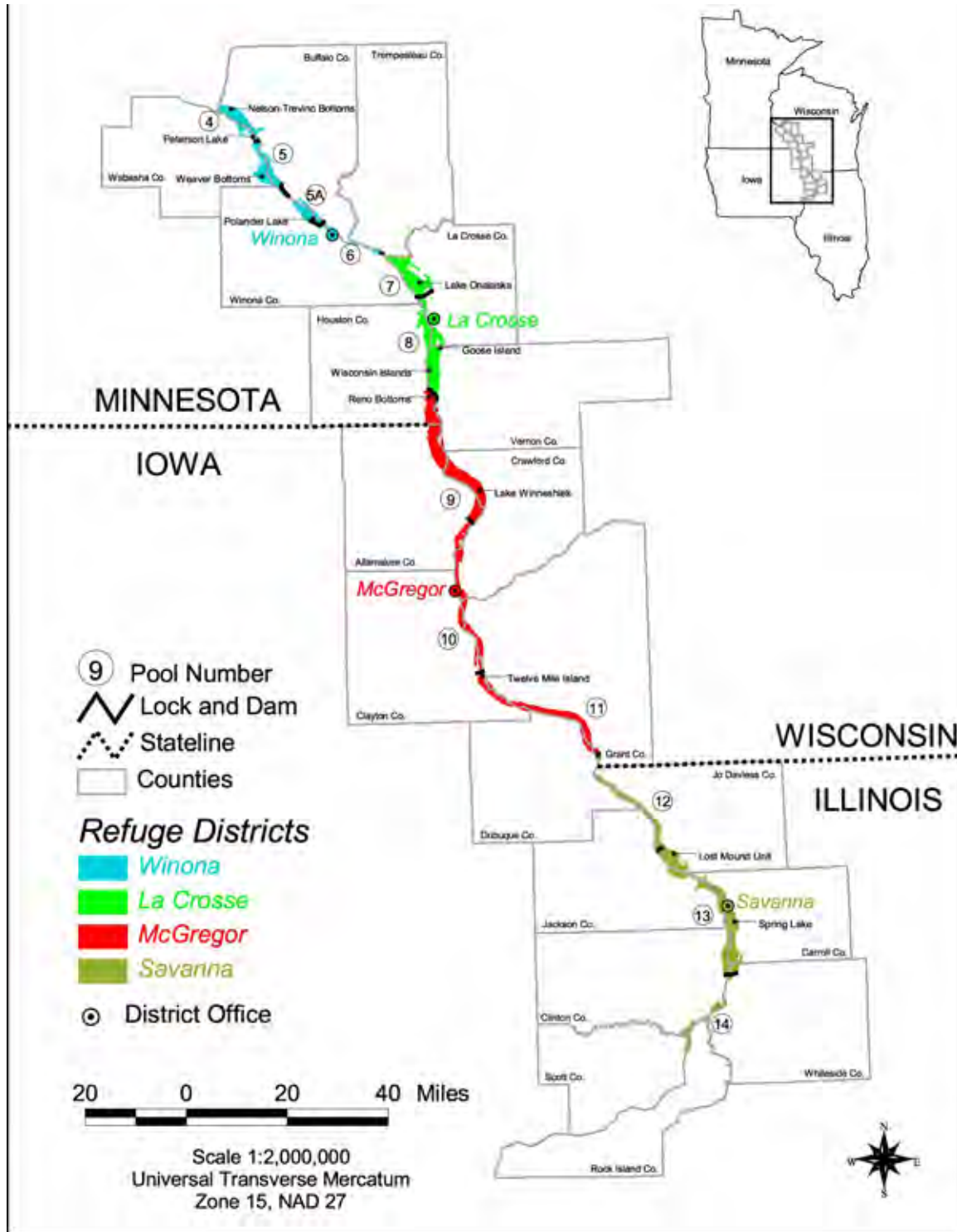

## **Exhibit 32**

Mississippi River Pool 14

**Princeton Slow, No Wake Area**  
 From March 16 through October 31, slow, no wake for watercraft and no alibots or hovercraft allowed.

**Access Points**

- 16 Rock Creek Ramp
- 17 Princeton Landing
- 18 10th Street Ramp
- 19 Princeton Ramp
- 20 Camp Hauberg Ramp
- 21 Port Byron Ramp
- 22 La Claire Ramp
- 23 Schuler's Shady Grove Ramp
- 24 Green Gables Boat Harbor

**Legend**

- Great River Road
- 712 Rivermile
- County Line
- State Line
- Navigation Channel
- Railroad
- Road
- Wingdam
- Refuge Land
- Non-Refuge Land
- Water
- Adjacent Public Land
- Slow No Wake Area
- Bike Trail
- Boat Landing
- Canoe Trail
- Wildlife Viewing Area

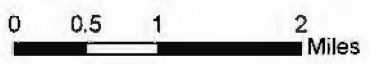
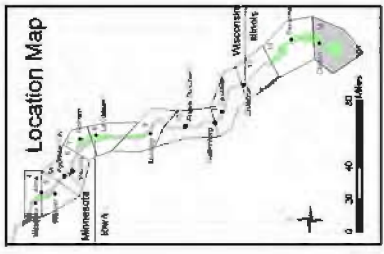

Boundaries posted in the field supersede all boundaries shown on maps.

**U.S. Fish & Wildlife Service**  
**Upper Mississippi River**  
*National Wildlife & Fish Refuge*  
 Pool 14

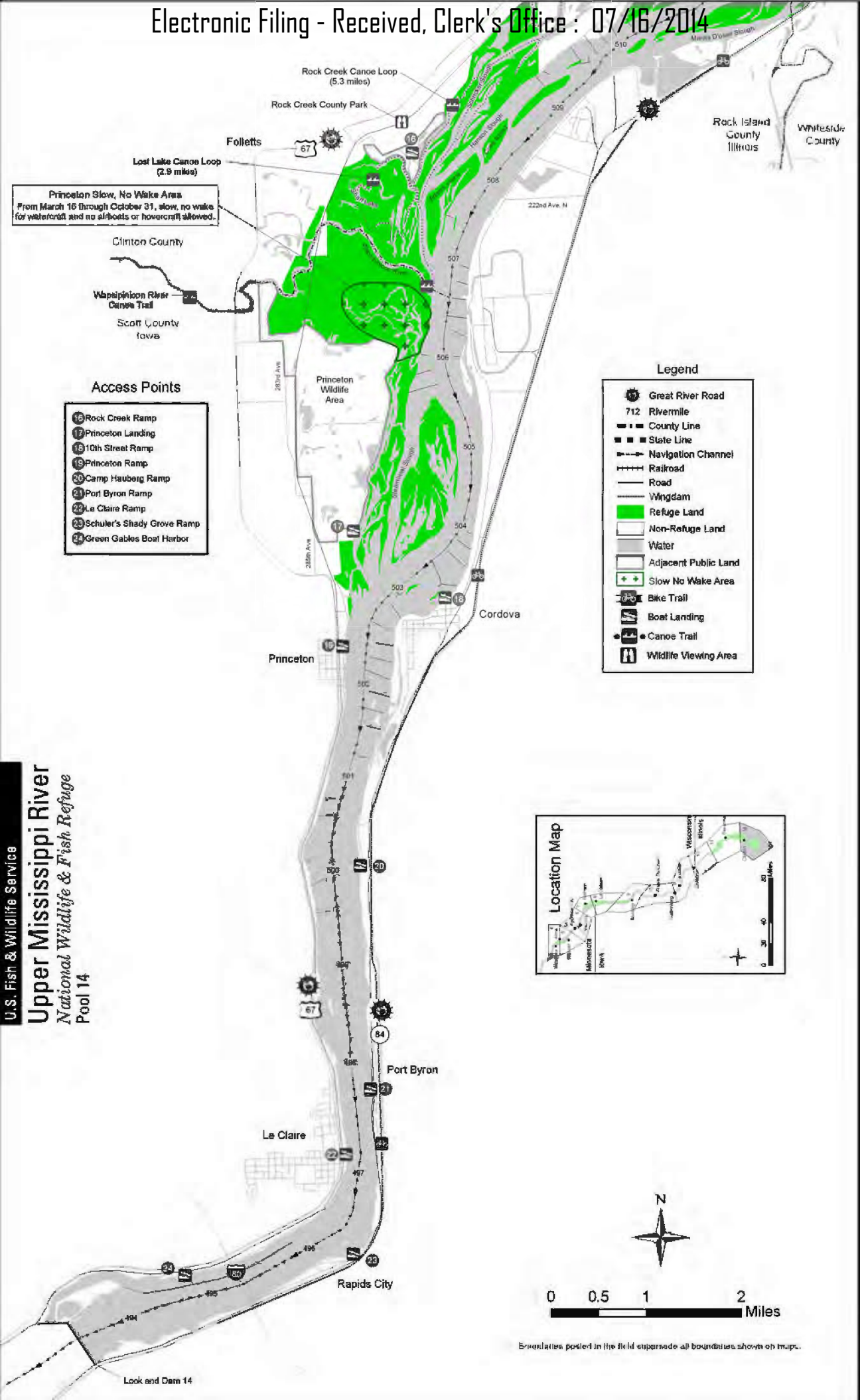

## **Exhibit 33**

Upper Mississippi River Fisheries Plan



# UPPER MISSISSIPPI RIVER FISHERIES PLAN 2010

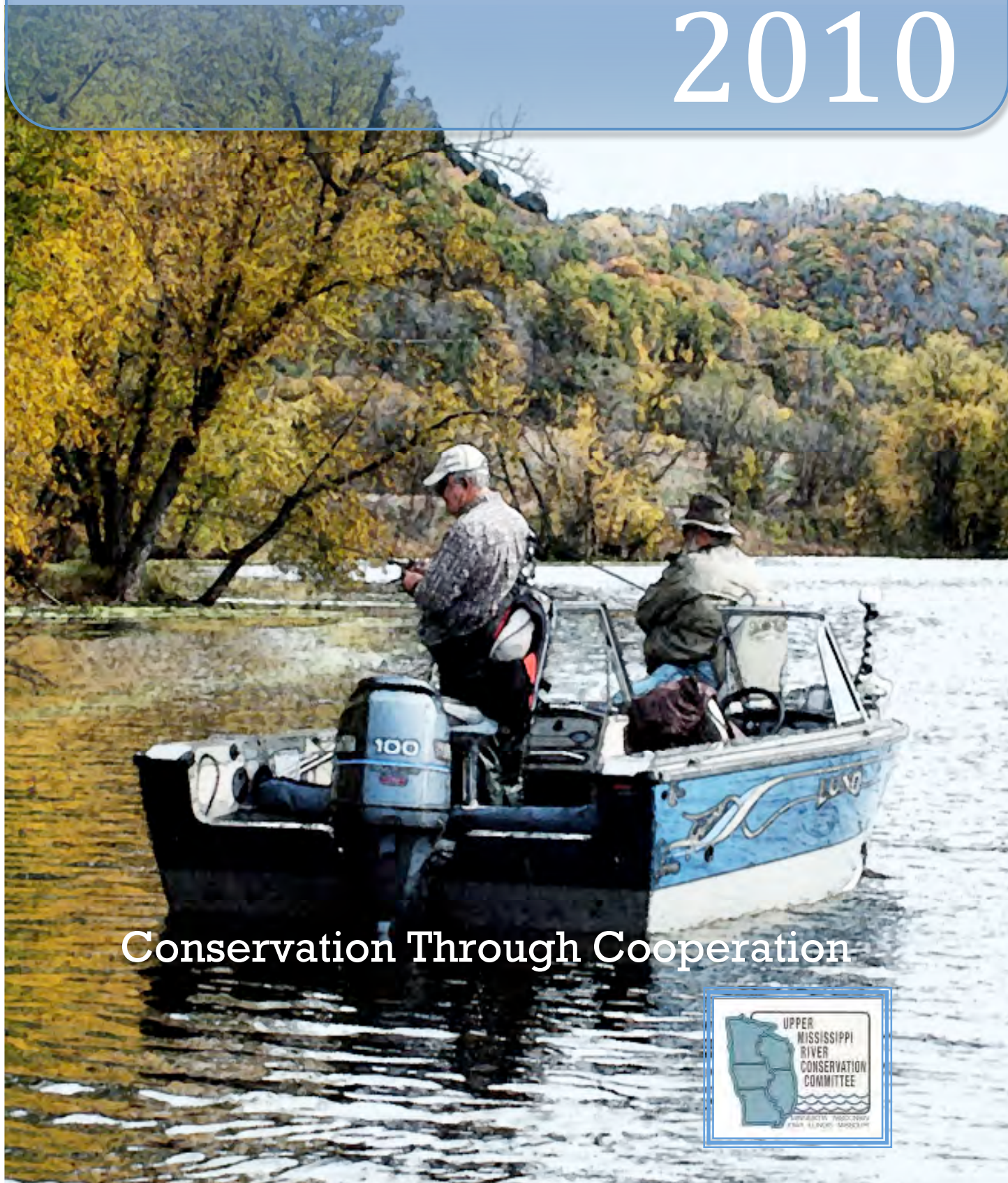

Conservation Through Cooperation

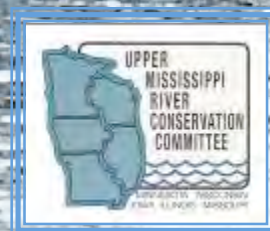

**Upper Mississippi River Conservation Committee**  
**555 Lester Ave.**  
**Onalaska, WI 54650**

Prepared by Fish Technical Committee Members:

Jeff Janvrin	Wisconsin Department of Natural Resources (Fish Section Chairperson)
Dan Dieterman	Minnesota Department of Natural Resources
Kirk Hansen	Iowa Department of Natural Resources
Dan Sallee	Illinois Department of Natural Resources
Travis Moore	Missouri Department of Conservation
Rick Frietsche	U.S. Fish & Wildlife Service
Ron Benjamin	Wisconsin Department of Natural Resources (Executive Board Chairperson)
Scott Yess	U.S. Fish & Wildlife Service (UMRCC Coordinator)
Tom Boland	Iowa Department of Natural Resources Retired (Facilitator)

Document Availability: This report along with an Executive Brief and a two-page summary pamphlet is available by contacting the UMRCC Coordinator, Onalaska, WI, or visiting the UMRCC website at <http://www.mississippi-river.com/>

Photos and Map Credits: Cover Photo, T.Boland; Photos Page 4, U.S. Fish & Wildlife Service, Wisconsin DNR,; Map Page 5, UMRCC; Photo Page 6, UMRCC; Photos Page 10, T. Boland, Missouri DOC; Photos Page 13, Iowa DNR, Missouri DOC; Photo Page 14, Wisconsin DNR; Photos Page 19, Wisconsin DNR; Photos Page 20, Wisconsin DNR; Photo Page 21, Wisconsin DNR; Photos Page 23, Wisconsin DNR, T. Boland, Iowa DNR, Missouri DOC; Photos Page 25, U.S. Fish & Wildlife Service, Iowa DNR; Photos Page 29, Wisconsin DNR; Photo Page 32, Wisconsin DNR.

Cited as: Janvrin, Jeff, et al. 2010. Upper Mississippi River fisheries plan 2010. Upper Mississippi River Conservation Committee. – Fish Technical Committee. Onalaska, WI. 36pp.

## TABLE OF CONTENTS

UMRCC Fishery Technical Committee Planning Team Members .....	2
Table of Contents .....	3
Message from the UMRCC Executive Committee Chairperson .....	4
The UMRCC Fisheries Plan Introduction .....	5
The UMRCC Fisheries Plan Impetus and Scope .....	6
About the Upper Mississippi River Conservation Committee .....	6
The UMRCC Fisheries Plan Goals and Priority Strategies .....	7
The UMRCC Fisheries Plan Goals, Objectives, Strategies, Performance Measures .....	9
Goal 1 - Restore and maintain the biological diversity of the Upper Mississippi River (UMR) biota and the richness of its native fish fauna .....	9
Goal 2 - Restore and maintain aquatic habitat and the ecological integrity of the UMR .....	14
Goal 3: Provide improved and sustainable recreational and commercial fishing opportunities on the UMR through unified UMRCC state management strategies .....	21
Goal 4 - Slow or eliminate the spread or introduction of aquatic nuisance species, including pathogens to the UMR .....	24
Goal 5 – Inform, educate, and involve the public in resource issues affecting the UMR .....	29
Literature Cited .....	33
Appendix A. Crosswalk of 1993 UMRCC UMR Fisheries Plan .....	34

**(NOTE: Appendix A is available as a separate document)**



## **A Message From the UMRCC Executive Board Chairperson**



**Greetings,**

**Managing the fishery of a river system like the Upper Mississippi that makes up the boundary of five states is a daunting task. Not only is it a very renowned and diverse world-class ecosystem, but also its management is multi- jurisdictional with often common or over-lapping responsibilities between state and federal agencies.**

**Many threats of today, such as the introduction of aquatic nuisance species, were almost unknown 25 years ago and likewise, some of the future threats are unknown today. The Upper Mississippi River Conservation Committee (UMRCC) in my mind is an organization that represents a very valuable forum to help better coordinate the management of this type of ever-changing natural resource.**

**This fisheries plan is the culmination of two years of hard work by many very dedicated people. I can't thank them enough for their efforts. It sets five broad goals with specific measurable objectives, strategies, and performance measures that give us a common point of reference to better manage this major aquatic resource into the future. Also, this plan will help us prioritize our fishery resource needs so that we can coordinate our work to get the best bang of the management effort for this magnificent resource that is being held in the public's trust.**

**It is my hope that we can use this plan to track our successes and learn from our mistakes and frustrations to help make this river "be the best that it can be". As the current UMRCC chairperson, I am extremely proud to roll this plan out. I encourage you to read it, discuss it, and ultimately use it for the betterment of OUR River, the Magnificent Mississippi.**

**Ron Benjamin**

## INTRODUCTION

### UMR

The Upper Mississippi River (UMR) is a very unique aquatic resource extending 926 miles from Caruthersville, MO upstream to Hastings, MN (1).



**Upper Mississippi River**

Excluding the Missouri River, the UMR drains approximately 189,000 square miles with a main-stem floodplain area of approximately 1.3 million acres (2). It is a riverine system of national and international significance and supports one of the most diverse and productive large river fisheries in the world. The UMR is home to approximately 164 species of fish and supports both a recreational and commercial fishery (3). Most fish species inhabiting the UMR are not considered to be either recreational or commercial, but all are equally as important for the continued health and maintenance of this truly magnificent aquatic resource.

The UMR has undergone several natural and human-induced changes. The number of demands placed upon the river are many and seem to be increasing every year. These demands are as diverse as the ecosystem itself. That is, we expect the river to provide us with many commercial, industrial, agricultural and recreational uses while continuing to support a healthy environment. We expect an abundant source of water for industrial, clean drinking water and public use (such as the dilution of wastewater). In 1986, the UMR was designated by Congress as both a nationally significant ecosystem with five National Wildlife Refuges and a nationally significant navigation system. Balancing these demands and uses while striving to maintain a healthy ecosystem is certainly a daunting and challenging task.

Each of the five UMR states (Minnesota, Wisconsin, Iowa, Illinois and Missouri) and federal agencies has its own resource management responsibilities and specific fisheries programs for its portion of the Upper Mississippi River. However, because of state boundary limitations, these individual programs create a challenge when addressing fisheries resource needs for the entire UMR. Therefore, in order to achieve a sustainable balanced approach, it is imperative that agencies assigned management responsibilities continue to take a holistic and coordinated approach for resource management. It must also be recognized that the responsibility for attaining this sustainable balanced approach must fall on all the users, developers, resource managers, decision makers and the general public.

This fisheries plan is a necessary step to that end. The plan is intended to recognize the UMR as one large riverine ecosystem and to identify the total resource needs while making recommendations to address them. It is also intended to serve as a necessary step toward identifying and fulfilling the short-term needs while looking toward the long-term requirements for sustaining a healthy fisheries resource. Ultimately, this plan will help provide the tools necessary to

chart the future direction for a sustainable UMR ecosystem.

## PLAN IMPETUS AND SCOPE

This strategic fisheries plan was developed out of a necessity to update a previous plan, the *Upper Mississippi River Fisheries Plan 1994-2003*, which was written by members of the UMRCC Fish Technical committee in 1993 (2).



### Previous Fisheries Plan

The early plan was written to cover a 10-year period. In order to write a new plan, another Fish Technical Committee subgroup was formed and a facilitator engaged to assist with the effort. Much of the previous plan has been incorporated; however, this updated version will focus mainly on fishery concerns and issues. Therefore, when other strategic plans such as those for water quality, freshwater mussels, or the U.S. Fish and Wildlife Service Comprehensive Conservation Plan for the Upper Mississippi River are available, those concerns and issues will be referenced to the appropriate plan, but not included in this document. In addition, each of the plan goals is generally structured in three sections that include: 1) determining and documenting the current

status of the goal; 2) developing a process to address the goal needs, and; 3) monitoring and evaluating the process. Finally, it is the intention of this fisheries strategic plan to define and update those concerns and issues that will help chart a clear path: a path that will provide the necessary holistic approach for river resource management while ensuring a healthy UMR fishery into the future.

## ABOUT THE UMRCC

The Upper Mississippi River Conservation Committee (UMRCC) was formed in 1943 by 22 fisheries biologists and natural resource managers with an interest in conserving the fish and wildlife resources of the Upper Mississippi River (4). In 1948, the UMRCC Executive Board was established along with technical committees that included fisheries, wildlife, water quality, recreation, and law enforcement. Recently, a new committee has been added to replace the recreation committee and education ad hoc committee called outreach, recreation, environmental education and interpretation technical committee (OREIT). Sub-committees now include publications and commercial fish while ad hoc committees are vegetation and freshwater mussels. Over the years, the member states of Illinois, Iowa, Minnesota, Missouri and Wisconsin have joined forces with the U.S. Fish and Wildlife Service, U.S. Army Corps of Engineers, U.S. Environmental Protection Agency and others to provide continuing cooperation between conservation and regulatory agencies responsible for fish, wildlife and recreation management on the UMR (5). The present membership has grown to more than 200 resource managers including state, federal and non-governmental agencies. Therefore, an important role for the UMRCC continues to be to provide a forum for discussion and resolution of the many management issues facing the present day Upper Mississippi River. This dedicated group remains committed to ensuring that the UMR will continue to be an environmentally healthy ecosystem, while providing a sustainable source of food, recreation, and commercial needs for future generations (4).

## **UMRCC Objectives and Guiding Principles**

**To promote the preservation and wise utilization of the natural and recreational resources of the Upper Mississippi River**

**To formulate policies, plans and programs for carrying on cooperative surveys and studies**

**To keep necessary records, publish and distribute reports**

**To make recommendations to the governing state bodies in the furtherance of the objectives of the UMRCC**

## **UMRCC Fisheries Plan Goals and Priority Strategies for a Sustainable UMR Fishery**

The Upper Mississippi River is one of the most renowned, productive, diverse, highly iconic riverine ecosystems in the world. There are enormous challenges facing the UMR with its many needs and public expectations. In addition, no single governmental agency has total control over its management. There is, due to state and federal laws, a multi-agency effort to manage the resource where jurisdiction and management responsibilities often overlap.

### **UMRCC Fisheries Plan Goals**

- 1. Restore and maintain the biological diversity of the Upper Mississippi River (UMR) biota and the richness of its native fish fauna.**
- 2. Restore and maintain aquatic habitat and the ecological integrity of the UMR.**
- 3. Provide improved and sustainable recreational and commercial fishing opportunities on the UMR through unified UMRCC state management strategies.**
- 4. Slow or eliminate the spread or introduction of aquatic nuisance species, including pathogens, to the UMR.**
- 5. Inform, educate, and involve the public in resource issues affecting the UMR.**

## **UMRCC Fisheries Plan Implementation**

As an organization, the UMRCC cannot achieve several of the objectives identified in this plan. However, the UMR state and federal agencies ultimately do have the legal authority to implement and achieve many of the objectives, strategies and performance measures outlined. It is the intention of this fisheries strategic plan to define the needs and priorities that will provide the necessary holistic approach for river resource management while ensuring a healthy UMR fishery into the future. To help in this effort, the following high priorities were derived from strategies or performance measures selected from each of the five goals.

### **UMRCC Fisheries Plan High Priorities**

#### **Priorities selected from Goal 1**

**Prepare an action plan for restoring and maintaining the relative abundance and species richness of the native Upper Mississippi River fishery. (PM 1.2.5)**

**Develop a standardized methodology for assessment of fishery community response to restoration actions at appropriate scales. (PM 1.5.3)**

#### **Priorities selected from Goal 2**

**Develop reasonable and measurable habitat based goals and objectives to be incorporated into a variety of Upper Mississippi River planning efforts and restoration, enhancement and maintenance management actions. (ST 2.2.2)**

**Identify critical fish habitat such as overwintering, spawning, etc. for enhancement and/or protection. (PM 2.2.2)**

#### **Priorities selected from Goal 3**

**Review existing Upper Mississippi River fish data and develop a population status and relative abundance scale from “optimum” to “minimally sustaining” fishing opportunities. (ST 3.1.1)**

**Monitor and evaluate fishing activity to determine the impact on the Upper Mississippi River Fishery. (ST 3.4.1)**

#### **Priorities selected from Goal 4**

**Prepare a listing of UMR species and associated habitats currently which are at risk or becoming impaired due to aquatic nuisance species and pathogens. (PM 4.2.1)**

**Establish a UMRCC Aquatic Nuisance Species Committee under the Fish Technical Section that will track ANS issues and programs. (ST 4.3.1)**

#### **Priorities selected from Goal 5**

**Identify river-related, public groups along the Upper Mississippi River and share information with them via meetings, letter, or email as needed. (ST 5.3.1)**

**Produce and distribute to the public UMR related literature using printed and electronic formats. (PM 5.3.2)**



## **GOALS, OBJECTIVES, STRATEGIES AND PERFORMANCE MEASURES**

### **Goal 1 - Restore and maintain the biological diversity of the Upper Mississippi River (UMR) biota and the richness of its native fish fauna.**

The Upper Mississippi River (UMR) serves many roles. It provides a commercial navigation system to transport much of the country's agricultural products, supports many municipal and industrial needs, and provides a variety of recreational uses. With this diversity of uses and demands comes many ecosystem management challenges and a strong need to conduct resource assessments on a regular basis. These assessments are needed to help improve the design of conservation and management plans and to evaluate their effectiveness.

According to last count, the fish assemblage of the UMR is represented by 164 species in 29 fish families (3). Sixty-four of those species are considered common to abundant in a pool or river reach (3). In order to determine and evaluate the diversity and richness of the native fish fauna on the UMR, a considerable amount of money and time commitment is needed. Most river management agencies collect some kind of data annually in an effort to evaluate and better understand the resource. However, long-term monitoring efforts are almost non-existent due to time constraints and budget restrictions. In 1858, the Illinois Natural History Survey began one of the nation's first and oldest biological monitoring programs. In 1957 began an annual monitoring program of the fish populations of the entire Illinois River (6). The Minnesota DNR initiated a long-term fisheries monitoring program on the UMR Pool 4 (Lake Pepin) and has collected gill net data starting in the mid 1960's (7). The Iowa DNR conducted a long-term fisheries monitoring program in three UMR pools for approximately 20 years before ending. Other agencies have conducted short-term studies generally based on short-term needs.

The backbone of UMR ecosystem assessments is the Long-Term Resource Monitoring Program (LTRMP). LTRMP is a federally funded program that was initiated in 1986 and involves the UMRCC states and several federal agency partners. Information from a number of biological components is collected and a variety of gear has been deployed to collect fish stock assessments in six UMR areas. By last count, approximately 3 million fish have been collected representing 134 species (8). The LTRMP periodically summarizes the data collected to describe biological, physical and chemical indicators of river conditions over a long-term period (presently 9 to 12 years). This information is widely distributed through publications and the Upper Midwest Environmental Sciences Center (UMESC) website and becomes extremely valuable in understanding and assessing the selected UMR biological trends.

The most recent LTRMP Status and Trends Report focuses mainly on measuring changes in potential indicators of UMR health as derived from LTRMP data. The report states: "Ideally, indicators should be derived from management objectives that define desired future conditions for the UMR and identify target levels for those indicators. However, no common set of goals and objectives has been formally adopted by UMR stakeholders. Informally, river managers have indicated that the future should be characterized by improved habitat quality and diversity, a closer approximation of the predevelopment hydrologic regime, and a diverse biotic community composed mainly of native species. River regulation, sedimentation, and floodplain development are generally considered the primary stressors affecting river habitats. Clearly articulating ecosystem goals and objectives

for a system as large, diverse and complex as the UMR is exceedingly difficult, yet critically important for assessing management options and, ultimately, defining success (8).”

It has been stated that after nearly 60 years of existence, the resource managers of the UMR still do not have sufficient information to manage some of the more important river fishes (8). The major conclusion to be drawn

regarding UMR fish stock assessment is that although it is very time-consuming and expensive, it is extremely valuable and necessary in order to better understand the ecological condition of the resource. A better understanding of the resource will be a critical component to helping restore and maintain the biological diversity of the UMR biota and the richness of its native fish fauna.



**Objective 1.1** – To document the current status of native and non-native UMR fish fauna by geomorphic reach.

Strategy 1.1.1 - Compile local and system-wide UMR fishery surveys (literature and field) to identify the following:

- a) The number of species that are protected or are in need of protection under state or federal statutes.
- b) The probable reason(s) for the changes in abundance and distribution.
- c) The distribution and relative abundance of all other UMR fish species.

Performance Measure: Publish a report on the distribution and relative abundance of UMR fish and mussel species by geomorphic reach.

**Objective 1.2** – To restore biological potential of native fish fauna by geomorphic reach to the populations that existed before and immediately after the construction of the nine-foot navigation channel.

Strategy 1.2.1 – Compile existing records of the relative abundance of fish populations prior to, and five to ten years following the completion of construction of the 9-foot navigation channel. Compare these data with the report prepared in 1.1.1.

Performance Measure: Prepare a document in table form that describes a comparison of these data.

Strategy 1.2.2 – Identify assemblages of native fishes and the characteristic features of their habitats.

Performance Measure: Develop a web-based report of fishery assemblages and characteristic features of their habitats using existing data and professional experience.

Performance Measure: Promote and support studies and monitoring to better understand relationships between UMR fishery assemblages and habitat features.

Strategy 1.2.3 – Identify the environmental roles of native fish assemblages (i.e. goods and services) and important abiotic and biotic mechanisms that determine reproduction and recruitment.

Performance Measure: Develop a web-based conceptual model of environmental factors influencing UMR fisheries recruitment and survival using existing data and professional experience.

Strategy 1.2.4 – Set goals for the relative abundance and species richness of UMR fish populations by geomorphic reach using the data prepared in Strategies 1.2.1, 1.2.2, 1.2.3, and professional judgment.

Performance Measure: Develop and publish goals by UMRCC using the documents prepared in 1.1.1, 1.2.1, 1.2.2 and 1.2.4.

Strategy 1.2.5 – Identify fish assemblages that require management action and the type of action needed to meet or maintain goals set in 1.2.4.

Performance Measure: Prepare an action plan for restoring and maintaining the relative abundance and species richness of the UMR fishery based on the goals set in Strategy 1.2.4.

**Objective 1.3** – To promote and participate in the assessment and implementation of management actions to maintain and/or enhance habitat needs identified in Strategy 1.2.5.

Strategy 1.3.1 - Incorporate information obtained from Objective 1.2 into designs of habitat rehabilitation enhancement projects (HREPs).

Performance Measure: Improve the fishery community response to habitat management actions by utilizing the best scientifically-based information available.

Strategy 1.3.2 - Incorporate the maintenance of habitat complexity into designs of future river management structures and mitigation plans.

Performance Measure: Promote the inclusion of habitat objectives that maintain and restore a diversity of habitats and fish species assemblages into all project planning.

Strategy 1.3.3 – Implement endangered species recovery plans.

Performance Measure: Include objectives and measures identified in endangered species recovery plans in project planning as alternatives.

Strategy 1.3.4 – Adopt and support the strategy for implementation of the wildlife action plan.

**Objective 1.4** – To identify and promote implementation of actions that maintain genetic integrity within fish populations.

Strategy 1.4.1 - Educate regional fishery managers about the potential threats confronting fish populations with a homogeneous or genetically- narrow gene pool.

Performance Measure: Develop UMR fish stocking guidelines and submit to UMRCC Executive Board for approval.

Strategy 1.4.2 – Develop a recommendation between UMRCC states that any fish stocking into the UMR be discussed and agreed upon prior to occurrence.

Performance Measure: Review the existing UMR fish stocking guidelines periodically and provide any recommended actions to the UMRCC Executive Board.

Strategy 1.4.3 – Promote the enactment of regulatory statutes restricting artificial gene flow (i.e. stocking) among disjoint populations until such time as the acceptable level of gene flow among population can be determined.

Performance Measure: Review state and federal stocking policies and laws periodically to ensure that all regulatory statutes are being followed.

**Objective 1.5** – To monitor the relative abundance and richness of the UMR fish fauna by geomorphic reach.

Strategy 1.5.1 – Support ongoing and future monitoring and research that will contribute to our understanding of the status of UMR fishery abundance and distribution.

Performance Measure: Promote UMR monitoring funding levels sufficiently to conduct systemic surveys.

Performance Measure: Identify potential methods to enhance availability and compatibility of fisheries data collected by UMR agencies.

Strategy 1.5.2 – Support and participate in coordinated monitoring of species richness to detect short and long-term trends at appropriate scales.

Performance Measure: Support and promote enhancement of current state and federally-funded fishery monitoring efforts.

Performance Measure: Support and participate in interagency cooperative monitoring efforts and record summary of efforts during annual technical section meetings.

Strategy 1.5.3 - Develop methodology to better assess fishery community changes due to habitat restoration actions.

Performance Measure: Develop a standardized methodology for assessment of fishery community response to restoration actions at appropriate scales.

Performance Measure: Implement a recommended methodology to assess predicted responses of assemblages of native fishes to habitat management actions on the UMR.



**Restore and maintain the biological diversity of the UMR biota and the richness of its native fish fauna.**

## **Goal 2 - Restore and maintain aquatic habitat and the ecological integrity of the UMR.**

The UMR Habitat Needs Assessment Report (HNA) states: "There is a broadly recognized need among resource managers and scientists for improved habitat quality, increased habitat diversity, and a closer approximation of pre-development hydrologic regime (9)." Perhaps no other statement better supports the desire and need for maintaining the diverse aquatic habitat and the ecological integrity of the UMR.

The UMR ecosystem has undergone many natural and human-induced changes. Most of the natural changes have occurred over thousands of years, while human-induced changes are of relatively recent origin. The expansion and development of human use within the river basin have significantly modified its physical and biological characteristics. As we continue to change the character of the river and alter the natural physical processes, the necessary natural elements for the maintenance of life and well-being of all riverine inhabitants is severely disrupted.

Sedimentation has been identified as one of the largest problems facing the Mississippi River (2). Sediment input occurs primarily through non-point source pollution attributable to agricultural and urban land use practices. The improvements to commercial navigation (including the construction of 29 navigation dams and other human activities) have increased sedimentation and effluent into the system, diminishing the quantity and quality of riverine habitat. Pooled areas of the UMR, especially backwaters, are most susceptible to sediment deposition (1). It is estimated that sediments are accumulating at an average of two cm per year in UMR backwaters. In addition, since 1930, Lake Pepin has lost an estimated 12% of its volume due to sedimentation (2). Thus Mississippi River backwaters, which are the most productive habitat for fish and wildlife, may be lost within 50 to 100 years (10).

Generally, both the quantity and quality of aquatic habitat(s) in the majority of pools on the UMR are diminishing. These changes are due to the inevitable aging of the man-made navigation pools and the environmental impacts associated with the numerous human uses of the system. The Habitat Needs Assessment (HNA) estimated that there are approximately 1,121,608 acres of habitat on the UMR and identified approximately 623,831 acres of that habitat to be in need of maintenance and/or restoration (9). In addition, navigation-related activities, flooding regimes, sedimentation, and land and recreational use have major effects on the river's ecosystem. Resulting physical changes will impact the abundance, distribution and diversity of all aquatic inhabitants including fish.

In 1986, the Upper Mississippi River Environmental Management Program (EMP) was authorized by the U.S. Congress for approximately \$33M per year to address both the need for monitoring and habitat enhancement of the UMR. It has been very successful and continues to be one of the worlds' showcase environmental programs on large river systems (8).

Therefore, it is imperative that critical and high priority habitat needs for each river pool and reach are determined so that necessary steps can be taken to protect or enhance them. A better understanding of the cause and effect relationships between river organisms and their habitat is needed before a prediction can be given regarding the future of the UMR. Quality riverine habitats are essential in order to maintain the rich and diverse UMR fish community. It is certain that the estimated cost of needed habitat maintenance and improvements on the UMR is high at approximately \$909M (2002 dollars) over the next 50 years and will double by 2050 if no action is taken (11). Likewise, it is also certain that the cost of not maintaining UMR aquatic habitats for future generations is almost immeasurable.

**Objective 2.1** – To document the historic and current distribution, quality, availability and status of habitats utilized by native fishes of the UMR.

Strategy 2.1.1 – Review, and if necessary develop, standardized terminology and definitions (for systemic and reach scales) to describe various habitat and geomorphic features of the UMR.

Performance Measure: Publish a report of standardized habitat and geomorphology terminology for use and citation by river management community and partners.

Strategy 2.1.2 – Review, and if necessary update, assessment of the number and types of different habitats needed for the aquatic community based on Biodiversity Objectives 1.3, 1.4 and 1.6.

Performance Measure: Publish a report and/or relational table of reach and pool availability for seasonal habitat needs of UMR fish utilizing definitions developed from Strategy 2.1.1.

Strategy 2.1.3 – Determine the historic and current distribution, quality, availability and status of UMR fisheries habitat.

Performance Measure: Publish a report of historic and current status and distribution of UMR fisheries habitat by reach and pool based on data from extant publications and professional experience.

Strategy 2.1.4 – Identify natural and human-induced beneficial and detrimental ecological disturbances affecting the distribution, quality and availability of fisheries habitats within the UMR floodplain.

Performance Measure: Publish a report based on data from extant publications and professional experience of historic, current and potential ecological disturbances by habitat type.

Strategy 2.1.5 – Identify “gaps” in the distribution, quality and/or availability of habitats that are, or are projected to be, limiting the ecological potential and integrity of the UMR fisheries community.

Performance Measure: Publish a report of existing and potential habitat gaps.

Strategy 2.1.6 – Identify additional data needed, at multiple spatial and temporal scales, to enhance ability to assess the distribution, quality and status of UMR aquatic habitats.

Performance Measure: Publish a report of data needed to enhance assessment of the distribution, quality and status of UMR habitats.

Performance Measure: Provide a report of data needs for consideration to partnerships when developing research proposals and data acquisition work plans.

**Objective 2.2** – To establish reasonable habitat-based goals and objectives appropriate for use in system, reach, pool and project scales to benefit fisheries habitat and ecological integrity.

Strategy 2.2.1 – Review existing state, federal and UMRCC strategic/implementation plans to identify goals and objectives that will benefit habitat and ecosystem integrity.

Performance Measure: Incorporate, as appropriate, the development of habitat-based goals and objectives for the betterment of the fishery.

Strategy 2.2.2 – Develop reasonable and measurable habitat-based goals and objectives to be incorporated into a variety of UMR planning efforts including restoration, enhancement and maintenance management actions utilizing information from Objectives 2.1 and 2.2.

Performance Measure: Publish a web-based report of habitat goals and objectives with appropriate and measurable physical and biological performance indicators.

Performance Measure: Identify critical fish habitat such as overwintering, spawning, etc. for enhancement and/or protection.

**Objective 2.3 – To protect UMR aquatic habitat from further human-induced degradation.**

Strategy 2.3.1 – Increase awareness of the need to protect and maintain existing quality habitats and habitat complexes identified in 2.1 and other state and federal plans.

Performance Measure: Publish a web-based report, with maps, indicating areas that the UMRCC and partners have identified as high quality habitats.

Strategy 2.3.2 - Utilize existing permit and enforcement authorities to protect existing habitat and to reduce rate of habitat degradation (i.e. 401, 404 and Sec 10 permits).

Performance Measure: Enforce federal, state and local permits.

Strategy 2.3.3 – Inform and educate state and federal agencies about watershed management and how it affects habitat diversity and ecological integrity within the UMR floodplain.

Performance Measure: Promote and support studies and monitoring to better understand relationships between watersheds, UMR habitat and ecological integrity.

Performance Measure: Publish web-based reports highlighting key relationships between watershed “health” and health of the UMR.

Strategy 2.3.4 – Support watershed initiatives to reduce/eliminate watershed-induced degradation of UMR habitat and ecosystem integrity.

Performance Measure: Promote efforts to minimize erosion in the watershed.

Strategy 2.3.5 - Prevent the degradation of UMR fisheries habitats that may be caused by current and future commercial and recreational navigation.

Performance Measure: Complete and implement short and long-range site plans in coordination with USACOE for the placement of dredged material in the UMR.



Performance Measure: Continue the ongoing “Avoid and Minimize Program” in coordination with USACOE for the channel maintenance program for the entire UMR.

Performance Measure: Publish guidelines in coordination with USACOE identifying ways to benefit the river's fishery with dredge material.

Performance Measure: Promote and support studies and monitoring to better understand relationships between navigational impacts and effects on UMR fishery resources and aquatic habitats.

Strategy 2.3.6 – Stabilize eroding shorelines with a variety of techniques to protect existing habitat.

Performance Measure: Develop standard guidelines, design criteria, etc., in cooperation with the COE, for enhancing the fisheries productivity and diversity in conjunction with shoreline stabilization.

Performance Measure: Protect eroding shorelines using a variety of techniques such as rock riprap, fallen tree anchoring and revegetation.

**Objective 2.4** – To implement proven and experimental management actions to restore, enhance and maintain UMR aquatic habitat diversity and ecological integrity, consistent with habitat goals and objectives identified in 2.2 and state and federal fishery plans.

*(Note: The following management action strategies to improve habitat are based on recommendations presented in the UMRCC's report entitled, “A Preliminary Description of Habitat Objectives (And Estimated Costs) Needed to Achieve a Desired Level of Ecosystem Integrity on the Upper Mississippi River” (11).*

Strategy 2.4.1 – Promote evaluation and implementation of changes to dam operating procedures in order to facilitate more natural hydrographs (i.e. reduced daily fluctuations).

Performance Measure: Publish a report, in cooperation with the COE, identifying UMR locks and dams where changes in dam operation would be feasible in order to facilitate a more natural hydrograph.

Performance Measure: Implement revised dam operating procedures where feasible and cost effective.

Strategy 2.4.2 – Promote development and implementation of watershed management actions to facilitate a more natural tributary hydrograph.

Performance Measure: Publish a web-based report highlighting how restoration efforts on the UMR may be limited due to tributary hydrograph impacts.

Performance Measure: Participate in, and contribute information to, watershed planning teams and their efforts.

Strategy 2.4.3 – Promote the use of water level stage reductions by geomorphic reach and implement water level management techniques by pool during the vegetation-growing period, May – September.

Performance Measure: Implement water level stage reductions where feasible and cost effective.

Strategy 2.4.4 - Restore longitudinal migration opportunities for fish in the main-stem Mississippi River through changes in dam operations and fish passage structures.

Performance Measure: Plan and construct fish passage structures at locks and dams on the UMR main stem where feasible and appropriate.

Performance Measure: Change dam operations, where feasible, to allow "open river" conditions during spring and early summer at as many dams as possible.

Performance Measure: Increase numbers of historic migratory fish species (i.e. skipjack herring) and other large river species (i.e. lake and pallid sturgeon, and paddlefish).

Strategy 2.4.5 – Promote restoration of fish passage at dams and other human-induced barriers on tributary rivers and streams that impact fish movement from the mainstem of the Mississippi River.

Performance Measure: Increase the number of "barrier-free" tributary streams.

Strategy 2.4.6 – Restore and enhance lateral floodplain connectivity to increase seasonal fisheries use on publically-owned properties and willing private ownerships.

Performance Measure: Produce a web-based product that provides managers and private landowners information and contacts for various voluntary programs and funding sources in order to facilitate voluntary implementation of floodplain land/use changes along the UMR which benefit habitat and ecosystem diversity.

Performance Measure: Increase the number of acres of privately-owned UMR floodplain enrolled in voluntary conservation programs.

Strategy 2.4.7 – Remove or optimize fish use of channel maintenance control structures in all geomorphic reaches.

Performance Measure: Develop standard guidelines for design criteria, in cooperation with the USACOE, for enhancing the fishery productivity and diversity of channel maintenance structures.

Performance Measure: Remove or modify the number of wing dikes and/or closing dams in each geomorphic reach.

Performance Measure: Remove or modify the channel maintenance revetment in each geomorphic reach.

Strategy 2.4.8 – Restore secondary channels (through modification of channel training structures, land acquisition from willing sellers, levee setbacks, dredging, embankment modification, etc.).

Performance Measure: Increase the number of miles of secondary channels restored or enhanced by pool and reach.

Strategy 2.4.9 – Restore or construct floodplain landforms (seed islands, chevrons, full-scale islands, reefs, etc.) in locations where floodplain structural diversity is needed to increase variability in flow patterns, sediment composition, bathymetry and reductions in wind fetch.

Performance Measure: Increase the bathymetric, sediment and velocity diversity within landform zone of influence.

Performance Measure: Decrease the wind fetch within landform zone of influence.

Strategy 2.4.10 – Dredge contiguous and isolated backwaters to restore or enhance off-channel fisheries habitat.

Performance Measure: Increase the number of contiguous and isolated backwaters meeting fishery life history needs by pool and reach.

**Objective 2.5** – To continue assessing the effectiveness of achieving goals and objectives to restore and maintain aquatic habitat and the ecological integrity of the UMR.

Strategy 2.5.1 – Identify additional data/research needed to understand how known natural and human-induced ecological disturbances affect fisheries habitat and communities.

Performance Measure: Prepare a report identifying additional data and research needs.

Strategy 2.5.2 – Identify data/research needed to establish a baseline of UMR fisheries habitats and community structure that can be used to assess changes due to unknown future natural and human-induced ecological disturbances.

Performance Measure: Continue to support and participate in interagency monitoring programs (i.e. UMR EMP Long-Term Research Monitoring Program, EPA EMAP, etc.).

Strategy 2.5.3 – Develop standardized methodology for assessment of achieving goals and objectives for attaining the desired ecosystem integrity at multiple scales.

Performance Measure: Work with partnership to develop standardized objective-based assessment methodology.

Performance Measure: Incorporate standardized assessment methodology into project performance monitoring.



**Restore and maintain aquatic habitat and the ecological integrity of the UMR.**



**Restore and maintain aquatic habitat and the ecological integrity of the UMR.**

### **Goal 3: Provide improved and sustainable recreational and commercial fishing opportunities on the UMR through unified UMRCC state management strategies.**

A concern for the possible overharvest of the river's commercial fishery and the need to maintain a sustainable resource during the war years was one of the major reasons that the UMRCC was formed in 1943 (4).

Construction of the 29 locks and dams in the late 1930's and early 1940's created impoundments. These impoundments expanded availability of permanently inundated aquatic habitat into which many fish populations rapidly expanded. As populations increased, so did the importance and value of both the recreational and commercial fishery.

Commercial fish harvest data has been collected annually by the UMRCC member states since 1945 and is summarized in UMRCC reports. This data may be the largest uninterrupted series of commercial fish harvest data found on any large river system in the world (1). Although the data set has limitations with no catch-per-unit-effort (CPUE) capability, it has been very helpful in providing much-needed information in order to better manage the resource.

Historically, commercial fishing on the UMR has provided a significant food source and monetary income to the region. Some commercial fish species have seen a decline in the quantity of fish harvested over the past 50 years. Data from the Long-Term Resource Monitoring Program (LTRMP) have shown that catch-per-unit-effort (CPUE) estimates from 1993-2004 for some species declined in some pools, while remaining stable in others (8). A possible cause for any decline in the reported harvest may be more market-driven than biological. There has been an increase in competition from farm-raised fish and an increase in the operation and material cost to the commercial fisherman without any substantial increase in retail price. In recent years, the demand and value of roe (eggs) from some fish species has far exceeded the value of the fish flesh. Examples would include both shovelnose sturgeon and

paddlefish. This significant increase in demand has forced resource managers to collect additional life history and harvest information for the species, and has encouraged them to consider a more holistic approach to better manage the resource. Even with the historic fluctuations in demand and harvest, the commercial fishery on the UMR continues to be a significant food resource, which adds to the regional economy and remains an important viable use of commercial fish species.

The interest in recreational or sport fishing on the UMR has seen major growth in the past few decades. Not only does the UMR provide diversity in sport species, but it also remains one of the world's most productive large river systems. The economic value of the recreational fishery far exceeds that of the commercial fishery. A total of 8,275,540 pounds of fish were reported caught by commercial fishermen in 2003 for a value of approximately \$2,301,586 (12). The estimated value of all recreational uses on the UMR which includes sport fishing was estimated at over \$1.2B (1990 dollars)(10,13). Sport fish creel harvest data from the UMR is limited and fragmented (1). However, with the cooperation of the UMRCC members, aerial counts, creel surveys, and more comprehensive recreational use surveys have been conducted on selected pools and years between 1973 and 1993.

Therefore, with the increase in attention to, and demand for both recreational and commercial fishing on the UMR, it will be necessary to continue collecting information for better understanding, while applying a holistic, multi-agency approach to better manage this uniquely valuable resource.



**Objective 3.1** – To continue to collect data to help determine the population status and relative abundance for key recreational and commercial fishes.

Strategy 3.1.1 – Review existing data and designate the population status and relative abundance along a scale from “optimum” to “minimally-sustaining” fishing opportunities.

Performance Measure: Document the population status and relative abundance of UMR fish in the form of a UMRCC report.

Performance Measure: Continue to collect data from “special projects” that will increase the knowledge of fish populations, life histories and other important parameters.

**Objective 3.2** – To establish population and relative abundance goals for key recreational and commercial fishes that are consistent across shared boundary waters.

Strategy 3.2.1 – Use data assembled in 3.1.1 to develop sustainable population and relative abundance goals.

Performance Measure: Incorporate the common population and relative abundance goals into state planning documents.

**Objective 3.3** – To establish and/or maintain common management strategies for key recreational and commercial fishes.

Strategy 3.3.1 – Incorporate features that sustain or improve fish populations and relative abundance into habitat improvement projects.

Performance Measure: Monitor and evaluate pre and post conditions of habitat improvement projects.

Strategy 3.3.2 – Establish uniform commercial and recreational fishing harvest regulations across shared boundary waters.

Performance Measure: Adopt uniform state regulations.

Strategy 3.3.3 – Establish uniform guidelines for recreational fishing tournaments across shared boundary waters on the UMR.

Performance Measure: Develop a uniform permit and reporting system that facilitates the monitoring and management of the impacts of tournament fishing on recreational fish populations.

Strategy 3.3.4 - Conduct periodic coordination meetings among border UMR states to discuss recreational and commercial fishing regulations.

Performance Measure: Discuss fisheries resource management issues and adopt uniform regulations among state regulatory authorities.



**Objective 3.4** – To determine the success of management actions for key recreational and commercial fishes.

Strategy 3.4.1 - Monitor and evaluate fishing activity to determine the impact on UMR fisheries.

Performance Measure: Establish and conduct measures (such as creel surveys) for monitoring angler success.

Performance Measure: Maintain and/or strive for uniform UMRCC commercial fish harvest reports with a summary on trends every five years.

**Objective 3.5** – To evaluate the need and potential for fish stocking in the UMR.

Strategy 3.5.1 – Determine and evaluate the existing fish stocking efforts in the UMR.

Performance Measure: Document the present fish stocking efforts in the UMR and lower reaches of major tributaries.

Strategy 3.5.2 – Determine a UMRCC fish stocking position in the UMR and develop general stocking guidelines.

Performance Measure: Prepare an annual summary of UMR fish stocking efforts and review of stocking guidelines.



## **Goal 4 - Slow or eliminate the spread or introduction of aquatic nuisance species, including pathogens, to the UMR.**

One of the first known introductions of aquatic nuisance species (ANS) to the Upper Mississippi River dates to pre-1883 when common carp were introduced (1). By the early 1890's this species had greatly increased in numbers, expanded its distribution and like many exotics, once introduced into a new environment, became highly detrimental to native populations.

More recently, several additional species of Asian carp have been introduced into the UMR (1). This list includes the grass, bighead, silver and black carp. All these species have either been introduced intentionally or accidentally, and all have expanded their numbers and range. The grass carp and black carp were thought to provide positive benefits by reducing unwanted vegetation in aquatic systems, or by reducing snail populations in commercial catfish production ponds. However, both species have the potential to cause detrimental impacts to the system (1). Likewise, silver and bighead carp have been introduced to the lower Mississippi River and a few individual fish have been documented as far upstream as Pool 4, Lake Pepin (14). All of these species are capable of growing to a very large size, and they compete for food at some trophic level with native fishes. Their negative impacts far outweigh any positive benefits that they were intended to provide. According to LTRMP fish collections, these aquatic nuisance species presently account for an annual proportion of native to non-native biomass of approximately 23 to 68% of the catch, with the common carp contributing the majority (72-98%) (8). Though LTRMP data from 1993-2004 indicates that common carp have been declining in the upper pools, it also indicates that silver and bighead carp numbers have increased in the lower pools and moving upstream (8).

Viral Hemorrhagic Septicemia (VHS) is a deadly and invasive virus that is threatening many fish. VHS first appeared on the U.S. West Coast in 1988 and was diagnosed in

the Great Lakes in 2005. VHS is considered to be a significant fish disease worldwide, and the Great Lakes strain is even more of a concern because it seems to affect a wide range of species. VHS could prove to be a serious threat to a broad range of native UMR fish species (15).

One of the most recent and devastating ANS introductions has been the zebra mussel. It is believed that zebra mussels were transported by and released from ocean-going ship ballast and introduced into the Great Lakes in 1988. By the early 1990's they were established in all the Great Lakes, transported down the Illinois River and spread throughout the UMR (1). It didn't take long before their populations exploded, and their ability to attach to hard substrate has caused millions of dollars' worth of damage and destruction to other aquatic fauna and their habitat. Mussel densities as high as 25,000 per square yard were reported in UMR Pools 9 and 10 in 1997 (5). The zebra mussels' presence and distribution in the Mississippi River Basin alone covers approximately 1.2 million square miles representing about 17% of the continental U.S. (1).

Present information indicates that aquatic nuisance species are tipping the natural balance of both the Great Lakes and UMR ecosystems. Additional potential invaders moving from the Great Lakes to the UMR include the spiny water flea, fishhook water flea, round goby and river ruffe (1). ANS moving from the UMR to the Great Lakes include the Asian carp species of grass carp, silver carp and bighead carp. A continued ANS exchange between the Great Lakes and UMR would be extremely detrimental to both ecosystems. Resource managers are becoming acutely aware of the need for a better understanding of the true dangers of allowing the continued introduction and expansion of aquatic nuisance species. If left unchecked, the continued introduction and spread of aquatic nuisance species has the potential to negate



any and all potential ecosystem protection, management or habitat enhancement gains that are being made. Therefore, in order to maintain a natural and healthy UMR ecosystem, it is imperative that we do the following: determine the status and

distribution of ANS to be monitored; evaluate the UMR fish species and habitats at risk; and take actions to prevent, control and eliminate further introductions of aquatic nuisance species or their pathogens.

---

**Objective 4.1** – To identify the status and distribution of aquatic nuisance species and pathogens known or suspected to be present on the UMR.

Strategy 4.1.1 - Support standardized monitoring activities designed to detect the status and distribution of aquatic nuisance species (i.e. goby roundup, zebra mussels, Asian carp) and pathogens on the UMR.

Performance Measure: Participate in ongoing and future aquatic nuisance species and pathogen monitoring activities. Provide annual updates of these monitoring efforts in the UMRCC newsletter and webpage.

Strategy 4.1.2 - Identify existing forums or groups tracking the status and distribution of aquatic nuisance species and pathogens.

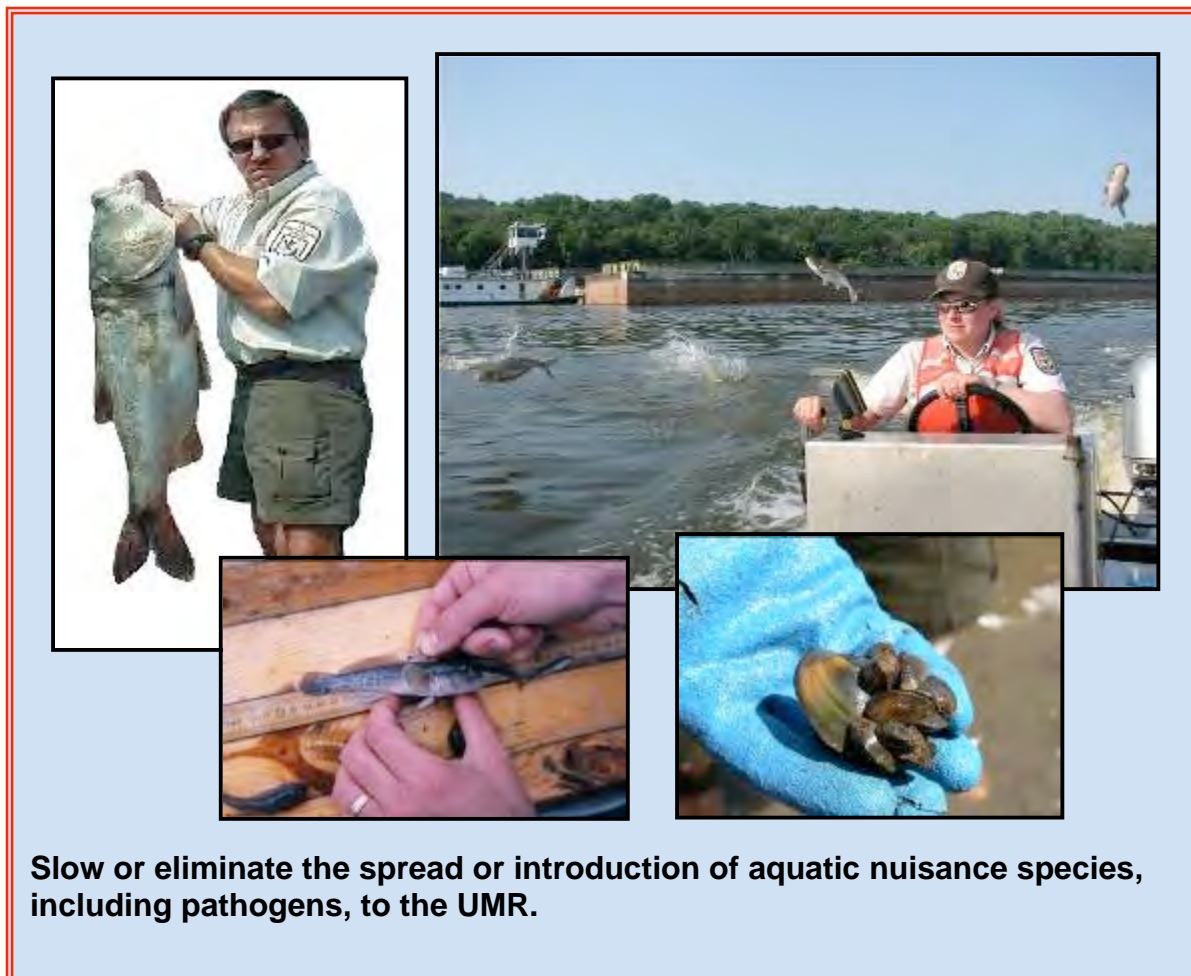

Performance Measure: Maintain a current status and distribution of aquatic nuisance species on the UMRCC webpage with links to organization and/or agency sites designed for reporting of aquatic nuisance species.

Strategy 4.1.3 - Report any requested information regarding the status and distribution of invasive species and pathogens on the UMR to existing aquatic nuisance species tracking networks.

Performance Measure: Participate in timely reporting of aquatic nuisance species status and distribution to appropriate reporting sites (i.e. NBII Invasive Species Sightings homepage: <http://invasivespecies.nbii.gov/report.html>).

**Objective 4.2 – To identify UMR fish species and habitats at risk and evaluate the impacts of aquatic nuisance species.**

Strategy 4.2.1 - Develop and/or review a list of UMR species and associated habitats that are at risk or are becoming impaired due to aquatic nuisance species and pathogens.

Performance Measure: Prepare a listing of UMR species and associated habitats currently at risk or becoming impaired due to aquatic nuisance species and pathogens. The list will be posted on the UMRCC website and updated as needed.

Strategy 4.2.2 - Develop criteria needed to evaluate the impacts of aquatic nuisance species on UMR species and their habitats.

Performance Measure: Review existing criteria for the evaluation of aquatic nuisance species' impacts on UMR habitat and biota, and post recommendations on the UMRCC website.

Performance Measure: Utilize standardized criteria, in cooperation with state, federal and non-governmental agencies, to evaluate the impacts of aquatic nuisance species.

**Objective 4.3 – To support efforts to prevent the introduction and establishment of aquatic nuisance species, including pathogens, to the UMR.**

Strategy 4.3.1 – Establish a UMRCC Aquatic Nuisance Species Ad Hoc Committee under the Fish Technical Section that will track ANS issues and programs.

Performance Measure: Establish an Ad Hoc Committee for aquatic nuisance species.

Strategy 4.3.2 - Participate in state and federal agencies' and NGOs' programs to prevent the introduction of aquatic nuisance species.

Performance Measure: Use and encourage best management practices that prevent the introduction of aquatic nuisance species.

Performance Measure: Continue participation with other agencies and groups (such as MICRA and Mississippi River Basin Panel on ANS) to support and develop policies and guidelines to prevent the introduction of aquatic nuisance species.

Strategy 4.3.3 - Support state and federal legislation that seeks to reduce or eliminate the introduction of invasive species, including pathogens.

Performance Measure: Review proposed legislation and provide science-based information concerning the potential impacts from aquatic nuisance species on the UMR.

**Objective 4.4 – To implement measures to control, reduce or eliminate aquatic nuisance species in the UMR.**

Strategy 4.4.1 - Support the implementation of surveys and research to assess the status, population and community changes caused by aquatic nuisance species in the UMR.

Performance Measure: Provide recommendations to appropriate funding sources in support of aquatic nuisance species research on the UMR.

Strategy 4.4.2 - Identify tasks in the Asian Carp Working Group's "Management and Control Plan for Asian Carp in the United States" that can be implemented by UMRCC members.

Performance Measure: Assist with tasks found in the plan.

Strategy 4.4.3 - Identify existing and proposed management practices used to control, reduce or eliminate aquatic nuisance species.

Performance Measure: Review research and management plans and projects for methods used to control aquatic nuisance species and pathogens, and post summary of findings on UMRCC website.

Performance Measure: Promote inclusion of contract language in agency-funded research and restoration projects that requires the "disinfection" of gear or other appropriate measures that limit the introduction or spread of aquatic nuisance species.

Strategy 4.4.4 - Support programs and research focused on the elimination or minimization of present populations of aquatic nuisance species.

Performance Measure: Review existing and potential invasive species and pathogen control methods and research; if warranted, provide science-based information concerning the UMRCC position on the control measures.

**Objective 4.5** – To promote the implementation of ecosystem restoration measures to restore ecosystem diversity which will increase the UMR resiliency to existing and future aquatic nuisance species introductions.

Strategy 4.5.1 - Provide support for existing and future programs focused on increasing UMR ecosystem diversity.

Performance Measure: Review existing and potential programs for restoration of the UMR ecosystem as needed and, if warranted, send appropriate correspondence expressing UMRCC's support.

Performance Measure: Promote the implementation of a variety of management actions to rehabilitate and enhance a socially and science-based desired ecosystem diversity on the UMR through implementation of strategies identified in Goals 1 and 2.

**Objective 4.6** – To increase public awareness of known and potential aquatic nuisance species on the UMR.

Strategy 4.6.1 - Implement strategies 4.1.4, 4.2.2, and 4.3.2.

Performance Measure: Design a user-friendly UMRCC website that can be used by both technical and public audiences.

Strategy 4.6.2 - Review existing materials and methods for promoting voluntary procedures preventing the spread of aquatic nuisance species, and develop additional materials if needed.

Performance Measure: Complete a review of the existing materials and methods in order to identify any needed changes.

Performance Measure: Develop and make available any additional materials needed to increase voluntary aquatic nuisance species prevention measures.

Strategy 4.6.3 - Review effectiveness of existing materials and methods promoting voluntary procedures in preventing the spread of aquatic nuisance species.

Performance Measure: Recommend assessment methods to determine voluntary compliance rates with aquatic nuisance species prevention measures.

Performance Measure: Promote inclusion of voluntary aquatic nuisance species and pathogen assessments into agency-funded user surveys on the UMR.

Strategy 4.6.4 - Develop an aquatic nuisance species page on the UMRCC website to increase awareness of potential aquatic nuisance species and pathogens.

Performance Measure: Promote actions that agencies, organizations and individuals can take to reduce ANS risk by providing links to related sites such as MICRA and Mississippi River Basin Panel on ANS.

## Goal 5 – Inform, educate, and involve the public in resource issues affecting the UMR.

An important aspect of this plan is to help inform and educate policy makers and the general public about concerns, issues and challenges facing the fishery of UMR. It is commonly accepted that people only understand what they are taught, tend to love what they understand, and are more likely to protect things that they love. If understanding, love and protection are desirable elements for the health and future of the UMR, then education and public outreach are a means to that end. Perhaps no other effort can reap as many benefits and rewards as knowledgeable UMR resource managers teaching others about the Upper Mississippi River.

To assist with this effort, the UMRCC Education Ad Hoc Committee was formed approximately 20 years ago when the Fish Technical Committee membership felt a strong need for public education and outreach. Since then a growing number of river biologists have organized and conducted numerous UMR education activities. They have included many festivals such as "Big River Days" in Missouri, "Take It to the River" in Iowa,

teacher workshops in Wisconsin and Iowa, and numerous talks and presentations up and down the river. It is obvious at these gatherings that people love to learn about the Mississippi River; who else is better prepared to teach about it than the many agency resource managers that work on the river every day and are responsible for its management? In the mid 1990's The UMRCC Education Ad Hoc Committee assisted with the production of a UMRCC video entitled "The Mighty Mississippi, A Balance of Integrity." The video won a major environmental award and still receives numerous accolades from other environmental groups.

In order to better understand and manage the UMR fishery, it will be necessary to maintain a well-informed public that understands and cares about the many issues facing the UMR. Recently, the UMRCC has broadened the scope of the education ad hoc committee by establishing a full standing committee called outreach, recreation, environmental education, and interpretation technical committee (OREIT).

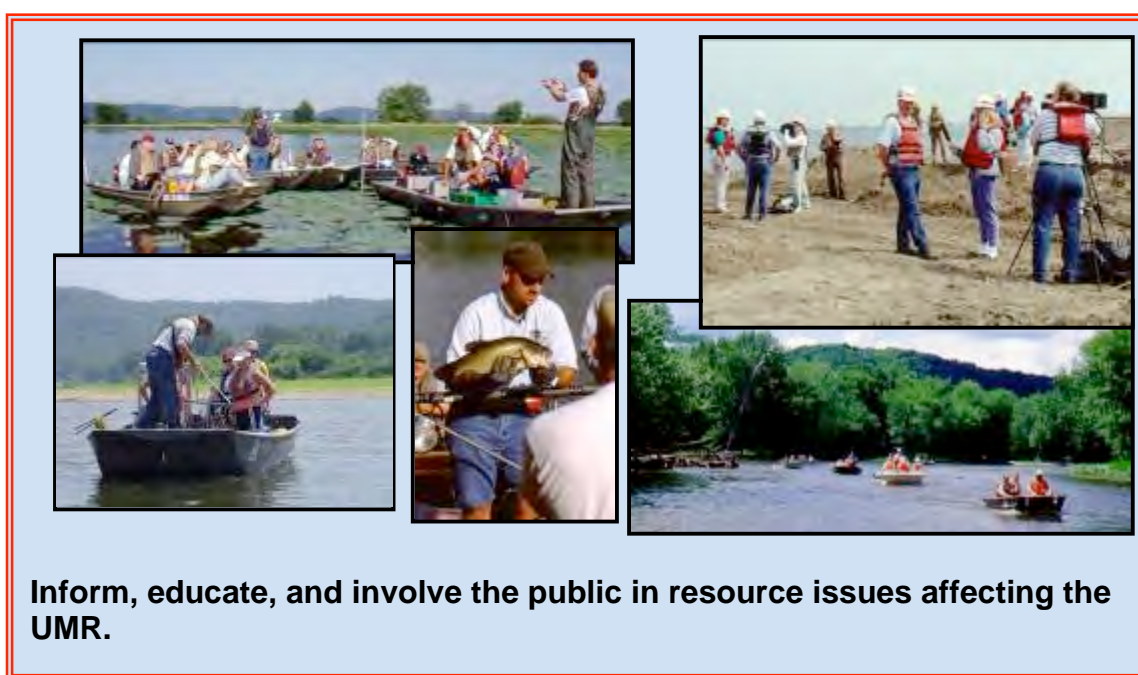

**Objective 5.1** – To broaden the scope and status of the UMRCC Fisheries Education Ad Hoc Committee by establishing a new standing committee.

Strategy 5.1.1 – Make technical committee chairpersons aware of the new standing committee which represents a cross-section of all UMRCC members' interests and encourage participation from all technical and ad hoc committees.

Performance Measure: Encourage all UMRCC technical sections and ad hoc committees to participate with the new standing committee.

**Objective 5.2** – To provide river-related information to media outlets along the UMR.

Strategy 5.2.1 – Work with the UMRCC membership to identify TV, radio, print and electronic media sources within 60 miles of the Mississippi River for distribution of UMR information materials.

Performance Measure: Compile a complete list of river-wide media outlets for distribution of UMR information materials.

Strategy 5.2.2 – Develop a list of local contacts from the UMRCC membership who are willing to be interviewed by local media concerning river issues.

Performance Measure: Complete and distribute media contact list to media outlets.

Strategy 5.2.3 – Add media sources to the UMRCC Newsletter distribution list.

Performance Measure: Determine if the media outlets listed in 5.2.2 are receiving the UMRCC newsletter.

Strategy 5.2.4 – Encourage river managers who write articles on river conservation to share them with the UMRCC coordinator for inclusion in the UMRCC newsletter, post them on the UMRCC website and individually distribute to river-wide media outlets.

Performance Measure: Distribute a list of river articles to media outlets and document any action in the UMRCC annual proceedings report.

**Objective 5.3** – To inform the general public of UMR programs and issues.

Strategy 5.3.1 - Identify river-related public groups along the UMR and share information with them via meetings, letters or emails as needed.

Performance Measure: Assist in gathering information on such groups by the UMRCC membership so that the UMRCC coordinator can include that information in the annual UMRCC proceedings report.

Strategy 5.3.2 – Support and help seek funding for the publication of electronic and printed river-related materials for distribution to the general public.

Examples could include but are not limited to: *Fishes of the Mississippi River* poster, *Freshwater Mussels of the Mississippi River* booklet, and, "The Mighty Mississippi, A Balance of Integrity" Video.

Performance Measure: Produce and distribute to the public UMR related literature using printed and electronic formats.

Strategy 5.3.3 – Continue to expand, update and maintain the UMRCC website.

Performance Measure: Update the UMRCC website monthly.

Strategy 5.3.4 – Provide presentations to various public groups on river issues.

Performance Measure: Record and report the number of river presentations in which UMRCC members participate and include a summary in the annual proceedings report.

Strategy 5.3.5 – Provide weekly river conditions and general fishing reports for the public and post on the website.

Performance Measure: Provide a weekly river condition and general fishing report update.

Strategy 5.3.6 – Offer general public "River Rat" memberships and include them in UMRCC mailings. Any funds generated will be used to further UMR research and educational efforts.

Performance Measure: Approve a public "River Rat" membership by UMRCC board and advertise to the general public.

Strategy 5.3.7 - Establish and initiate a public " UMRCC Conservationist Award" that recognizes outstanding contributions made by individuals or groups that exhibit outstanding service and dedication to the protection and wise use of the UMR natural resources and values.

Performance Measure: Establish a public "UMRCC Conservationist Award" that recognizes outstanding contributions for the protection and wise use of UMR resources and values.

**Objective 5.4 – To support the initiation of river-related events and festivals, and participate in these events as much as possible.**

Strategy 5.4.1 – Support and participate in the annual Mississippi River events, such as the Teacher's Workshop at Wyalusing State Park, WI, and assist with establishing similar events along the river.

Performance Measure: Encourage UMRCC members to participate in river workshops and special events.

Strategy 5.4.2 – Identify river-related specific events throughout the UMR and provide assistance to local UMRCC members to attend and display information regarding the river and the UMRCC. This may include financial assistance to cover booth space and/or expenses.



Performance Measure: Generate a list of UMR river events and support the participation of UMRCC representatives at those special events.

Strategy 5.4.3 – Provide promotional materials and/or financial assistance to river-resource groups that participate in public river awareness events at which a UMRCC member's presence is not possible.

Performance Measure: Require a report from the UMRCC partner groups on how the funds and materials were used at the event and the number of attendees.





### LITERATURE CITED

1. Rasmussen, J. L., and J.M. Pitlo, 2004. UMRCC fisheries compendium 3<sup>rd</sup> edition. Upper Mississippi River Conservation Committee – Fish Technical Committee. Rock Island, IL. 274pp.
2. Farabee, G., et al. 1993. Upper Mississippi River fisheries plan 1994-2003. Upper Mississippi River Conservation Committee. – Fish Technical Committee. Rock Island, IL. 27pp.
3. Steuck, M. 2009. Distribution and relative abundance of Upper Mississippi River fishes. Upper Mississippi River Conservation Committee – Fish Technical Committee (unpublished report). Onalaska, WI.
4. Upper Mississippi River Conservation Committee (UMRCC) website. Retrieved 31 August 2009 from <http://mississippi-river.com/umrcc/>.
5. Upper Mississippi River Conservation Committee. 2000. A river that works and a working river: a strategy for the natural resources of the Upper Mississippi River. Dan McGuiness editor. Upper Mississippi River Conservation Committee, Rock Island, Illinois. 40pp.
6. Illinois Natural History Survey website. Retrieved 31 August 2009 from <http://www.inhs.illinois.edu/>.
7. Meerbeek, J.R. 2007. Large lake monitoring program annual completion report: Lake Pepin, 2007. Minnesota Department of Natural Resources, Division of Fish and Wildlife, Section of Fisheries, Completion Report F-29-R(P)-27. 88pp.
8. Johnson, B.L., and K. H. Hagerty, editors. 2008. Status and trends of selected resources of the Upper Mississippi River. U.S. Geological Survey, Upper Midwest Environmental Sciences Center, La Crosse, Wisconsin, December 2008. Technical Report LTRMP 2008-T002. 102pp + Appendices A-B.
9. U.S. Army Corps of Engineers. 2000. Upper Mississippi River habitat needs assessment: summary report 2000. U.S. Army Corps of Engineers, St. Louis District, St. Louis, Missouri. 53pp.
10. About the Upper Mississippi River. Retrieved 20 January 2010 from [http://www.umesc.usgs.gov/umesc\\_about/about\\_UMR.html](http://www.umesc.usgs.gov/umesc_about/about_UMR.html).
11. Janvrin, Jeff. 2002. A preliminary description of habitat objectives (and estimated costs) needed to achieve a desired level of ecosystem integrity on the Upper Mississippi River. Upper Mississippi River Conservation Committee. Rock Island, IL. 22pp.
12. Upper Mississippi River Conservation Committee. 2007. Proceedings of the sixty-third annual meeting of the Upper Mississippi River Conservation Committee, Upper Mississippi River Conservation Committee. Onalaska, WI 107pp.
13. Economic impacts of recreation on the Upper Mississippi River. Retrieved 20 January 2010 from [http://umesc.usgs.gov/reports\\_publications/recstudy.html](http://umesc.usgs.gov/reports_publications/recstudy.html).
14. Kevin Stauffer (personal communication February 11, 2010) Minnesota DNR and Upper Mississippi River Conservation Committee – Fish Technical Committee Member.
15. Wisconsin Department of Natural Resources website. Retrieved 31 August 2009 from <http://dnr.wi.gov/fish/vhs/vhsfacts.html>.

**Appendix A. Crosswalk of 1993 UMRCC UMR Fisheries Plan (UMRCC 1993) objectives to 2010 UMRCC fisheries plan objectives. (Many of the 1993 objectives relate to several 2010 objectives due to reorganization of strategies within goals and objectives)**

1993 Goal	1993 Goal Text	1993 Objective Number and Text	2010 Objective Ref. Number
<b>1</b>	<i>Improve water quality of the UMR.</i>	1.0: By 1999 determine spatial and temporal water quality trends in the UMR.	UMRCC WQ Plan
		1.1: By 2000 assess the effects of water quality on the aquatic ecosystem.	UMRCC WQ Plan
		1.2 By 2001 have projects in operation that will enhance, restore, or maintain suitable water quality on the UMR.	UMRCC WQ Plan
<b>2</b>	<i>Increase the amount of suitable aquatic habitat in the UMR.</i>	2.0: By 1998 determine and assess the amounts of different habitats needed for the aquatic community.	1.2, 1.3, 2.1, 2.2, 2.5
		2.1: By 2000 slow natural and man-made processes that degrade habitats.	2.3
		2.2: By 2004 enhance, acquire, restore, maintain and develop additional aquatic habitats.	2.4
<b>3</b>	<i>Increase biologic diversity and improve the ecologic integrity of the UMR by restoring the River's dynamic flow-regime.</i>	3.0: By 2004 manage river flows to more closely approximate natural hydrologic regimes.	2.4
		3.1: Fully support and endorse watershed initiatives to restore hydrologic regimes within watersheds that incorporate sustainable land use practices by 2004.	2.3, 2.4
		3.2: By 2004 have programs in place to inform and educate state and federal agencies about the loss of biological diversity and the inability of the UMR system, as currently managed, to sustain a diverse biological community.	1.2, 1.3, 1.4, 2.3
<b>4</b>	<i>Maintain or improve biological diversity in the UMR.</i>	4.0: By 2004 take actions to ensure that rare or endangered fish and invertebrate species in the UMR are not extirpated from the region and that common species do not become rare or endangered.	1.1, 1.3, 1.4, 1.5, 2.3
		4.1: By 1999 develop ways to maintain genetic variability within fish populations.	1.4

Appendix A. Continued

5	<i>Maintain and improve populations of native fish and mussels in the UMR by slowing or eliminating the spread or introduction of exotic species</i>	5.0: By 2003, document and control the introduction of exotic fish and mussels in the UMR.	4.1, 4.2, 4.3, 4.4, 4.5, 4.6
6	<i>Maintain the characteristic elements and richness of the native fish fauna of the UMR.</i>	6.0: By 1997 identify assemblages of, and define some of the mechanisms that sustain, native fish species richness in the UMR.	1.1, 1.2
		6.1 By 2000 assess maintenance and enhancement programs for existing habitat complexity and features that sustain assemblages of native fishes and recreate critical habitat characteristics in river reaches where they are scarce.	1.3, 1.5, 2.5
		6.2 By 2000 develop management strategies to maintain or enhance existing habitat complexity and features that sustain assemblages of native fishes and recreate critical habitat characteristics in river reaches where they are now scarce.	1.2, 2.1, 2.2
7	<i>Provide improved sport and commercial fisheries on the UMR through unified UMRCC state management strategies.</i>	7.0: By 1998 institute creels, to be conducted every fifth year, on 5 UMR pools.	3.4
		7.1: By 1997 complete guidelines for achieving uniform commercial and sport fish and mussel harvest regulations between UMR state resource agencies.	3.2, 3.3, 3.4, UMRCC Mussel Plan
		7.2: By 1995 establish common objectives to manage key sport and commercial fishes of the UMR.	3.1, 3.2, 3.3, 3.4, 3.5
		7.3: By 1997 establish consistent commercial fish harvest reporting procedures among the UMRCC states.	3.3
		7.4: By 1998 develop fish stocking guidelines to improve and/or enhance UMR fish populations.	1.4, 3.5
		7.5: By 1999 complete a UMRCC Fish Technical Section "white paper" addressing sport fishing tournament impacts upon key UMR sport fishes.	3.3, 3.4
8	<i>Coordinate efforts to assure that UMR fishery resources and aquatic habitats are restored to their original biological productivity and protected from future navigation impacts.</i>	8.0: By 1999 determine the seasonal impacts of navigation and system management for navigation upon critical fish life history stages.	1.2, 2.4, 2.5

## Appendix A. Continued

<b>8</b> <b>(cont.)</b>		8.1: By 2000 eliminate fishery related impacts associated with the placement of nine-foot channel dredged material.	1.2, 2.4, 2.5
		8.2: By 2002 prevent the degradation of UMR fishery habitats that may be caused by future navigation expansion.	1.2, 2.1, 2.2, 2.3, 2.4
		8.3: By 1997 eliminate unregulated barge fleeting activities.	2.4
		8.4: By 1998 optimize the habitat value of channel maintenance regulating structures (i.e. wing-dikes, revetments, etc.) for fishery use.	2.4
		8.5: By 1997 develop guidelines to minimize the risk of barge related hazardous and toxic chemical spills to unique and sensitive fish habitats.	2.4
<b>9</b>	<i>No net habitat loss should be caused by River related development.</i>	9.0: By 1996 develop methods to cooperate with agencies and authorities to prevent or mitigate UMR habitat losses, and negative impacts on aquatic biota resulting from River development.	1.3, 2.2, 2.3, 2.4, 4.3, 4.4
		9.1: By 2000 improve public and private development interest's sensitivity to UMR ecosystem needs.	1.3, 2.3, 2.4, 4.3, 4.4
<b>10</b>	<i>Inform and educate the public on issues affecting the UMR basin.</i>	10.0: By 1995 develop a network for distributing information on key issues impacting UMR resources including, but not limited to, navigation, sedimentation, hydropower, shoreline development, regulations, user conflicts, sport and commercial fishing, and contaminants	4.6, 5.2, 5.3, 5.4
		10.1: By 1996 have in place processes to update and provide information on current issues and ongoing (or planned) activities that address each issue.	5.2, 5.3, 5.4
<b>11</b>	<i>Involve the public directly in addressing resource problems and needs.</i>	11.0: By 1998 identify specific actions that can be taken by the public to address resource problems.	5.4
		11.1: By 1999 identify and organize interested parties and individuals into groups with effective political and social input into UMR resource issues.	5.3

## **Exhibit 34**

Figure E-2

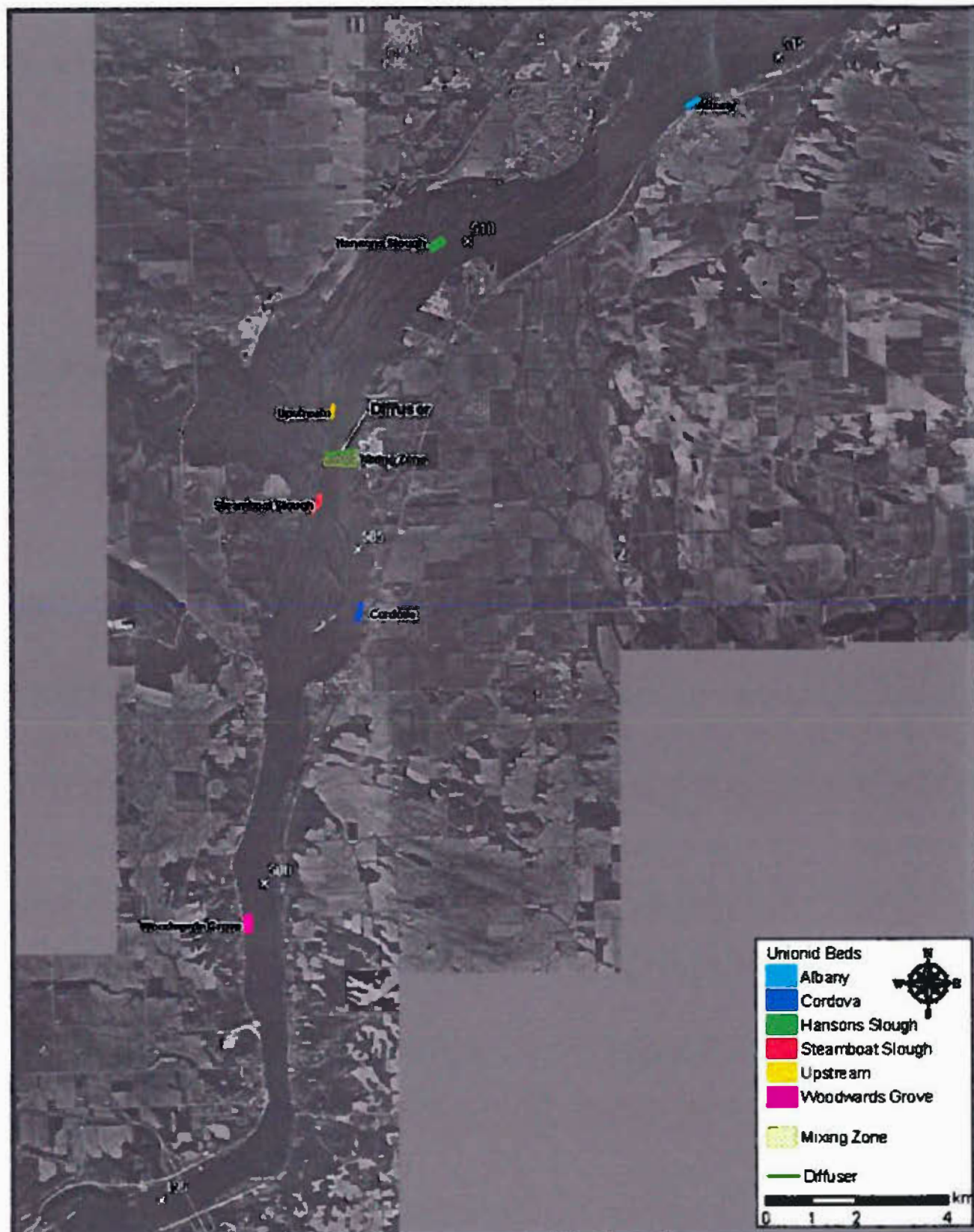



Hansens Slough

510  
x

Upstream

Diffuser



Mixing Zone

Samboat Slough

505  
x

Cardova

500  
x



## **Exhibit 35**

Iowa DNR Response to Draft 316(a) Demonstration





# STATE OF IOWA

CHESTER J. CULVER, GOVERNOR  
PATTY JUDGE, LT. GOVERNOR

DEPARTMENT OF NATURAL RESOURCES  
RICHARD A. LEOPOLD, DIRECTOR

April 7, 2010

Mr. Jeremiah J. Haas  
Principal Aquatic Biologist  
Exelon Nuclear  
22710 206<sup>th</sup> Avenue N.  
Cordova, IL 61242

**RE: Draft Demonstration Report in Support of Request for Alternative Temperature Limits  
Under Clean Water Act §316(a)**

Dear Mr. Haas:

The Iowa Department of Natural Resources (DNR), Fisheries Bureau has reviewed the *Final Draft Quad Cities Nuclear Station Adjusted Thermal Standard CWA Section 316(a) Demonstration* report dated November 2009. The DNR does not support a permit variance change to 3% exceedance of thermal standards. However we do appreciate the opportunity to review the draft report and provide input before the final report and variance request is submitted.

1. Most of the basis for your argument that the adjusted thermal standards (ATS) will have no impact on the aquatic resources of Pool 14 is made from your statement that no impacts were observed from the 2006 excursion event. A total of 222.75 hours were used during this event, however the ATS requests a 3% excursion limit (262.8 hours), an additional 40.05 hours. There is no information available to determine these additional hours of excursion may have. In fact, by your own admission (page A-36), long term chronic effects of the ATS are unknown. Additionally, similar ambient river levels and temperatures have been encountered in the past without the need for additional excursion hours. The difference between 2006 and those years is that the plant cut power generation thus reducing thermal outputs to the river. In 2005, we reviewed a draft proposal for ATS requesting a 3% excursion limit, but it was decided that a 1.5% excursion limit would be sufficient for long term plant operation while protecting the aquatic resources of Pool 14.
2. Despite your claim that the 2006 excursion event had no effects on fish populations around the QCNS, a fish kill did occur during that event. You have provided additional documentation that the kill occurred both above and below the station, but we have no documentation that kills occurred in any other area of the river. While the stations operations at that time may have not been the sole reason for the kill, it certainly exacerbated the situation and should be factored.
3. While you state, and we agree, that the ATS will not eliminate established recreation on Pool 14, it will certainly impact recreational fishing in areas of the pool. During excursions a long stretch of the river below the diffuser pipe is devoid or greatly reduced of fish as they avoid thermal stressors, thus reducing or eliminating angling opportunities in that stretch.

1. You claim that the 2006 excursion event had no measurable impact on the unionid communities downstream of the station. This is based on observations from mussel surveys conducted over the past several years on beds in the area of the plant. What is not stated is the statistical power of these surveys to detect changes in the mussel communities in these beds. Many times power to detect changes in these types of surveys only allows you to detect a 20% change 80% of the time. If your surveys had similar power, significant reductions could occur that may be undetectable under the current design. Inclusion of these statistics would greatly strengthen the draft. Additionally, the principle investigator on the mussel surveys, Heidi Dunn, had stated that she cannot support a 3% excursion hour limit as it will likely impact the unionid communities below the plant.
2. Table 2 of Appendix B on page B-23 references section 3.4 regarding bio-thermal analysis of the effects of increased thermal standards on Higgins-eye pearly mussels, but this section has been omitted from the report.

The DNR Fisheries Bureau is willing to support the increase to 1.5% that we agreed to in 2005. Please contact me at 515.281.6976 or [martin.konrad@dnr.iowa.gov](mailto:martin.konrad@dnr.iowa.gov) if you have questions or wish to discuss these comments.

Sincerely,

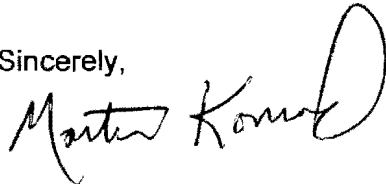

Martin Konrad  
Executive Officer II  
Fisheries Bureau

cc: John Dunn, EPA Region VII (via email)  
Kirk Hansen, IA DNR Fisheries Bureau (via email)  
Connie Dou, IA DNR Water Quality Bureau (via email)  
Steve Williams, IA DNR Water Quality Bureau (via email)

## **Exhibit 36**

Iowa DNR 1/20/2010 Letter re: Draft 316(a) Demonstration



CHESTER J. CULVER, GOVERNOR  
PATTY JUDGE, LT. GOVERNOR

## STATE OF IOWA

DEPARTMENT OF NATURAL RESOURCES  
RICHARD A. LEOPOLD, DIRECTOR

January 20, 2010

Mr. Jeremiah J. Haas  
Principal Aquatic Biologist  
Exelon Nuclear  
22710 206<sup>th</sup> Avenue N.  
Cordova, IL 61242

**RE: Draft Demonstration Report in Support of Request for Alternative Temperature Limits Under Clean Water Act §316(a)**

Dear Mr. Haas:

The Iowa Department of Natural Resources has reviewed the *Final Draft Quad Cities Nuclear Station Adjusted Thermal Standard CWA Section 316(a) Demonstration* report dated November 2009. We appreciate the opportunity to review this draft report and provide input before the final report and variance request is submitted. The following comments are provided on behalf of the department's Water Quality Bureau. Additional comments may be provided by staff in our Fisheries Bureau in a separate letter.

1. In Section 3.1.4 Exelon argues that Iowa has only an "advisory role" with respect to permitting facilities outside its borders and that any input to permitting decisions comes through certification under Section 401 of the Act. In making this argument, Exelon neglects the fact that the NPDES permit for the Quad Cities Station is jointly issued by both the Illinois EPA and the Iowa DNR as it has been since 1979. As such both states have equal say as to permit requirements including ensuring that the permit complies with each state's water quality standards. Exelon's discussion of the applicability of Section 401 in this case is irrelevant because Iowa has not been asked for nor has it provided water quality certification under Section 401 with regard to the NPDES permit. Instead, compliance with applicable provisions of state law that might occur under Section 401 in other circumstances is ensured by an NPDES permit jointly issued by both states. We request that this section be revised along with all other sections of the report to reflect Iowa's equal partnership with Illinois in the NPDES permitting process.
2. Since Iowa is an equal partner with Illinois in the NPDES permitting process it has equal input to any decision whether a variance is granted under CWA Section 316(a) and the conditions of such a variance. In order for both states to fulfill their responsibilities under the Clean Water Act we believe the 316(a) demonstration must address both Iowa and Illinois water quality standards. As written the demonstration addresses only the Illinois standards.

To remedy this we suggest that where a standard, or portion thereof, in the two states is identical the demonstration acknowledge this. Where the standard in each state is different the demonstration must either be based on the more stringent of the two standards, while acknowledging the existence of the less stringent standard, or it must address both standards separately. To assist you in this I have enclosed the temperature and mixing zone

criteria excerpted from Iowa Administrative Code 567-Chapter 61 that are applicable to the Mississippi River.

3. Appendix B, Section 1.3 explains how fish species were evaluated and finally selected for biothermal modeling. The report states that the starting point was a list of 93 species found in Pool 14 over a period of 32 years and explains how this list was pared down to the five (5) Representative Important Species (RIS) subsequently used in the assessment. While the discussion of how this paring was done is clear we recommend that the master list used as the starting point be included in the report as well.
4. In 2004 Exelon submitted a report by Forrest M Holly Jr, et. al. titled *River Temperature Predictions Downstream of Quad Cities Nuclear Generating Station*. The modeling results from this study were subsequently used to assess the risks of increasing the duration of excursion temperatures to unionid mussels and presented by Heidi Dunn in March 2006, *Unionid Mussel Biothermal Assessment for the Quad Cities Nuclear Station, Mississippi River Miles 503.0 to 506.9*. We believe the 316(a) Demonstration would be enhanced if it was revised to contain some of the information and graphics contained in Ms Dunn's presentation with similar graphics used to show potential areas of impact to fish as well.
5. Page A-10, paragraph 2: A portion of Mississippi River Pool 14 from the Wapsipinicon River to Lock & Dam 13 is also identified in the 2008 Iowa 303(d) list as impaired due to aluminum and nutrients.

Please contact me at 515.281.8884 or [steve.williams@dnr.iowa.gov](mailto:steve.williams@dnr.iowa.gov) if you have questions or wish to discuss these comments.

Sincerely,

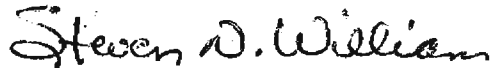

Steven N. Williams  
Environmental Specialist Sr.  
NPDES Section

Enclosure: Iowa Temperature Water Quality Criteria

- c: John Dunn, EPA Region VII (via email)  
Kirk Hansen, IA DNR Fisheries Bureau (via email)  
Martin Konrad, IA DNR Fisheries Bureau (via email)  
Connie Dou, IA DNR Water Quality Bureau (via email)

**Iowa Administrative Code Chapter 567  
Water Quality Standards**

**61.3(3) Specific water quality criteria**

(b)(5)5. No heat shall be added to the Mississippi River that would cause an increase of more than 3° C. The rate of temperature change shall not exceed 1° C per hour. In addition, the water temperature at representative locations in the Mississippi River shall not exceed the maximum limits in the table below during more than 1 percent of the hours in the 12-month period ending with any month. Moreover, at no time shall the water temperature at such locations exceed the maximum limits in the table below by more than 2° C.

Zone II – Iowa-Minnesota state line to the northern Illinois border (Mile Point 1534.6).

Zone III- Northern Illinois border (Mile 1534.6) to Iowa-Missouri state line.

Month	Zone II	Zone III
January	4° C	7° C
February	4° C	7° C
March	12° C	14° C
April	18° C	20° C
May	24° C	26° C
June	29° C	29° C
July	29° C	30° C
August	29° C	30° C
September	28° C	29° C
October	23° C	24° C
November	14° C	18° C
December	9° C	11° C